

Conf-930676--44

MICROWAVE INTERFEROMETRY TO ELUCIDATE SHOCK PROPERTIES

Gabriel G. LUTHER

Los Alamos National Laboratory, Los Alamos, New Mexico, USA, 87545

Barry J. WARTHEN

EG&G/EM, Los Alamos, New Mexico, USA, 87544

A series of measurements have been performed using a simple, lightweight, inexpensive, compact K-Band (SLICK) interferometer to measure the shock properties of passive (Teflon, grout) and energetic (HE) materials. Shock and particle velocity measurements are made simultaneously along the same path. This path is determined by either a thin walled (1/2 mil aluminum foil) waveguide embedded in the material or the caustic of a Teflon axicon. Typically the velocities are determined to about a percent. The measurements will be described and data presented.

RECEIVED
SEP 02 1993
OSTI

DISCLAIMER

This report was prepared as an account of work sponsored by an agency of the United States Government. Neither the United States Government nor any agency thereof, nor any of their employees, makes any warranty, express or implied, or assumes any legal liability or responsibility for the accuracy, completeness, or usefulness of any information, apparatus, product, or process disclosed, or represents that its use would not infringe privately owned rights. Reference herein to any specific commercial product, process, or service by trade name, trademark, manufacturer, or otherwise does not necessarily constitute or imply its endorsement, recommendation, or favoring by the United States Government or any agency thereof. The views and opinions of authors expressed herein do not necessarily state or reflect those of the United States Government or any agency thereof.

MASTER

DISTRIBUTION OF THIS DOCUMENT IS UNLIMITED

db

DISCLAIMER

Portions of this document may be illegible in electronic image products. Images are produced from the best available original document.

1. INTRODUCTION

A simple K-band microwave interferometer has been developed at the Los Alamos National Laboratory to measure various transient properties in both energetic (high explosive) and passive (grout and Teflon) materials. The interferometer measures the position as a function of time of either a dielectric discontinuity, i.e., a shock front, or the position as a function of time of a conducting surface such as the detonation wave in a high explosive. By embedding a reflector in a dielectric material, both the particle velocity and the shock velocity may be measured at the same time and in the same place.

2. INSTRUMENTATION

The interferometer (Fig. 1) (which evolved from an X-band interferometer²) is based on a 24 GHz Gunn diode oscillator, normally found in automatic door openers, etc., and a mixer diode pair obtained from the same company². The two mixer diodes, electrically one-quarter wave apart, yield quadrature components of the signal (sine and cosine) which are typically recorded on LeCroy 8818 CAMAC digitizers. In order to prevent frequency pulling of the Gunn diode by this reflector signal so as to resolve subwavelength position details, the mixer diode and the oscillator are separated by an isolator, sometimes using a commercial K-band isolator and sometimes using a three-port circulator and a dummy load; in some cases, a simple attenuator may be substituted to isolate the Gunn diode from the reflected signal. Usually, 6 to 10 db of attenuation is inserted in the waveguide between the mixer diode and the reflecting surface to be measured to balance the amplitudes of the transmitted and reflected signal.

The phase of the reflection is determined by two things: 1) The distance between the reflecting surface and the mixer diode, and 2) the index of refraction of the material between the reflecting surface and the mixer diode. In particle velocity measurements, the amount of refracting material between the reflecting surface and the mixer diodes is a constant and hence if $n-1$ is proportional to the density (the Gladstone-Dale approximation³) the travel necessary to give a 2π phase change at the mixer diode is the same as in vacuum (approximately 0.77 cm in a WR-42 waveguide). However, shock velocity measurements consist of a wave front (dielectric discontinuity) moving through a material medium and so the

index of refraction needs to be considered. The measured value in Teflon in a WR-42 waveguide for the length required to give the same 2π phase change is 0.45 cm. Since the shock wave is faster than the particle wave by very different frequency, the two signals may be recorded separately by either analog or digital filtering.

As examples of the range of uses of the interferometer, three measurements will be described. It has been used to measure the shock properties of the grout, the deflagration-to-detonation transition in a compacted powder explosive (both inside a waveguide) and an unconfined measurement of the detonation velocity in solid HE, the velocity of the explosion products at the interface of the explosive shock and air and the pressure at a Teflon surface upon which the explosive products impinge.

3. FIRST EXAMPLE

As a first example, pressure measurements in grout have been performed. A waveguide detector was constructed of one-half mil household aluminum foil the size of the inside of the WR-42 waveguide (0.170 x 0.420 in.), having Teflon inside and outside of the waveguide. An aluminum plate, one-eighth in. thick terminated the waveguide and was immersed in the grout. As the shock passed from the grout through the aluminum plate into the Teflon, the shock front produced the high-frequency signal seen in the data, i.e., the shock velocity, and the motion of the aluminum plate (and hence the grout and Teflon between which it was sandwiched) the low-frequency component in the data gave the particle velocity (Fig. 2). Analysis of these two signals fitted the Marsh Handbook⁴ data, showing that the Gladstone-Dale model is appropriate.

4. SECOND EXAMPLE

Another experiment done inside a waveguide is a measurement of the process by which deflagration transitions to detonation in a compacted powdered HE. A one-half-in. inside-diameter heavy-walled brass tube, which acted both to confine the explosive and as a circular waveguide, was packed with the powdered HE to a density of 1.25 gm/cm³. A Teflon plug covered with copper foil was shaped to form a reflectionless transition between the WR-42 waveguide and the brass tube and acted as a tamper on the powdered HE (Fig. 3). The HE was ignited with a pyrofuse so as to initiate

a slow burn. The burn, the compaction wave produced by the burning HE, and the deflagration-to-detonation transition and the detonation wave can be clearly seen (Fig. 4). In addition, the analysis of the shock and particle velocity signals in the Teflon plug give the pressure.

5. THIRD EXAMPLE

In this example, a free space measurement, a Teflon axicon⁵ was used to focus the microwaves from a horn through a 2-in. air gap and hence into a 2-in.-thick piece of solid HE (Fig. 5). A sheet of aluminum foil between the lens and the HE was the initial reflector. Figure 6 clearly shows the detonation front moving through the HE, the shock front generated as the HE products travel through the air gap, and the shock and particle velocities in the Teflon when the HE products impinge upon the Teflon. Since the equation of state of Teflon is well known, the pressure at the air-Teflon interface can be determined as in the First Example. The time of the initiation of the detonation in the solid HE and the time of the transition of the shock from the HE to the air could be accurately determined. Using these times and the length of the HE (2 in.), the velocity of detonation was determined with an accuracy of about one percent.

6. CONCLUSION

These techniques are still under development. It is possible (limited by the signal-to-noise ratio) to use the ratio of the amplitude of the shock signal to the amplitude of the particle signal to determine the index of refraction change at the shock front and hence to determine the change in density. This feature has not been fully explored. Frequency agile measurements are currently being made which give not only the velocity but the position from which the reflection emanates. Knowledgeable experimenters in this field can obviously find other uses for this SLICK apparatus.

ACKNOWLEDGEMENTS

We would be very pleased to acknowledge information from and conversations with Frank Harlow, George Nichol, John Moses, Blaine Asay, Gil Miranda, Stan Marsh, Joe Fritz and the technicians in the P-3 Group, Los Alamos National Laboratory.

REFERENCES

1. G. Luther, L. Veerer, B. Warthen, "A Microwave Interferometer to Measure Particle and Shock Velocities Simultaneously", Shock Compression of Condensed Matter-1991, S.C. Schmidt, R.D. Dick, J.W. Forbs, D.G. Tasker, Eds., Williamsburg, Virginia, June 17-20, 1991 (Elsevier Science Publishers B. V., 1992), pp. 775,778.
2. Alpha Industries, 20 Sylvan Road, Woburn, Massachusetts, 01801.
3. J. Wackerle, H. Stacy, J. Dallman, Proceedings of the SPIE, V. 832, San Diego, California , August 17-19, 1987, (SPIE, 1988), p. 76.
4. S.P. Marsh, LASL Shock Hugoniot Data (University of California Press, Berkeley, CA, 1980), pp.467-468.
5. J. McLeod, "The Axicon: A New Type of Optical Element", Journal of the Optical Society of America, v. 44, 8, (1954), pp.592-597.

FIGURE CAPTIONS

FIGURE 1

The interferometer showing the Gunn diode, the isolator, the attenuator and the waveguide leading to the detector.

FIGURE 2

The quadrature signals, sine and cosine, of the particle and shock velocity motions in grout.

FIGURE 3

Shows the WR-42-to-one-half-in. transition, the compacted HE, the pyrofuse that sets it off and the containment pieces.

FIGURE 4

Deflagration to detonation transition showing the slow burn initiated by the pyrofuse, the compaction wave generated by the slow burn, the instant of the onset of detonation and the detonation wave.

FIGURE 5

Third example instrumentation showing the axicon used to focus the microwaves, the horn, the air gap and the solid HE.

FIGURE 6

The data from the third example showing the passage of the detonation through the HE. It is possible to determine accurately the time it takes to transit the two inches and, from that, the velocity to within 1%.

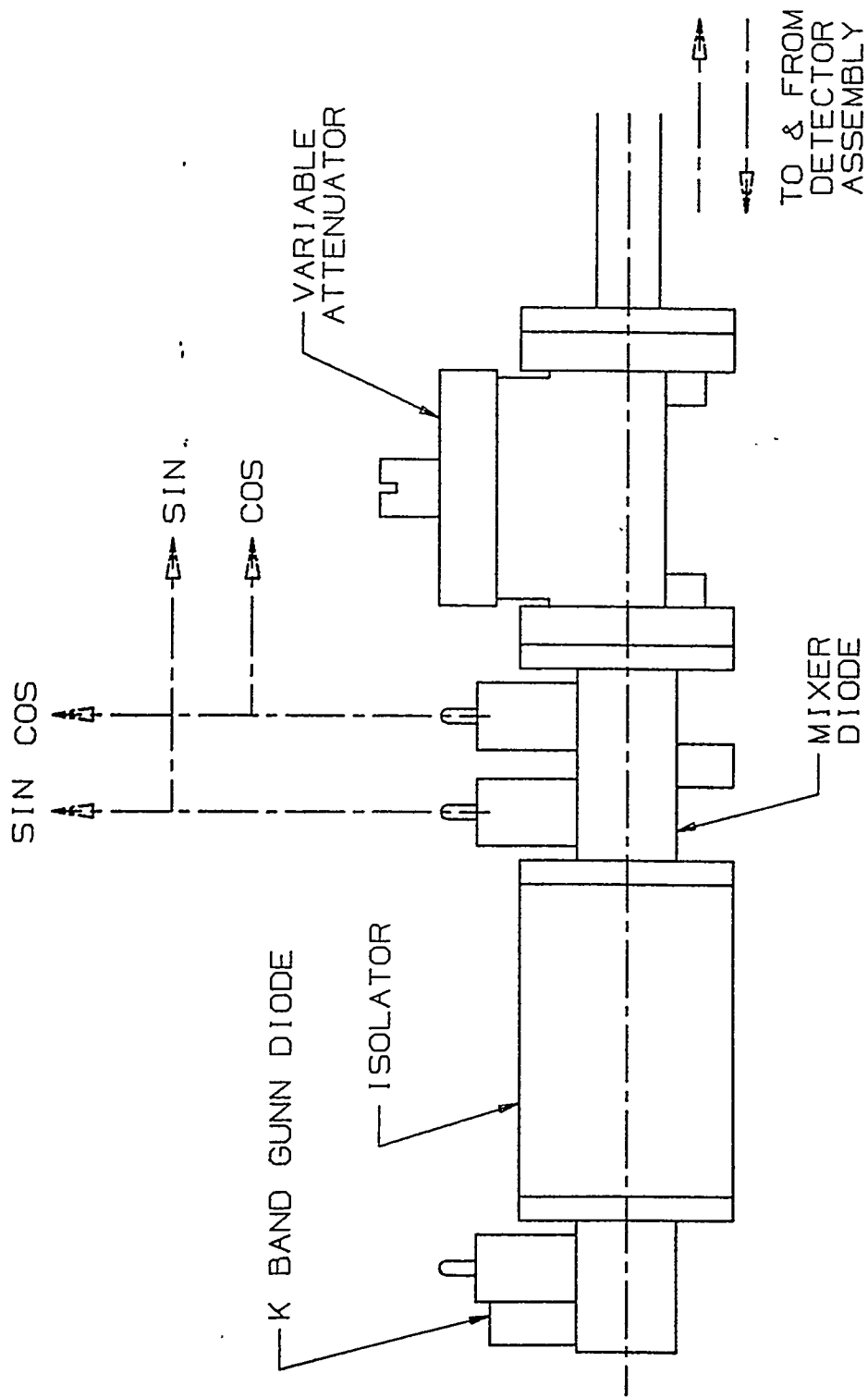

Fig 1

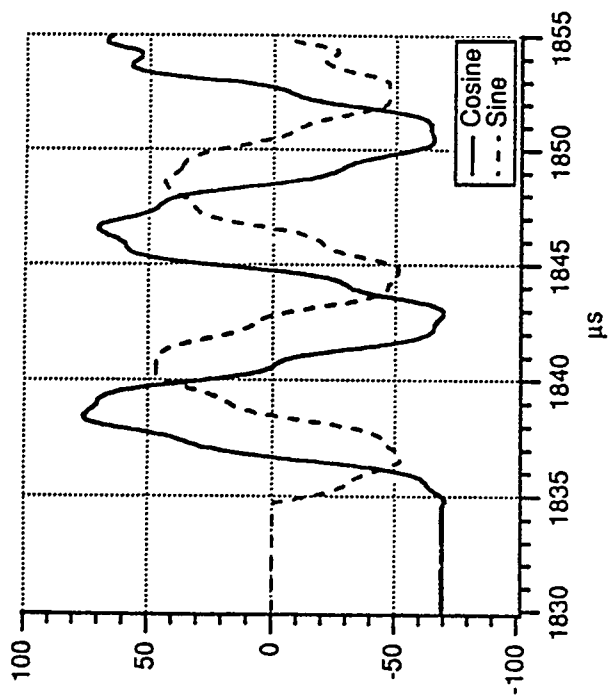

FIG. 2

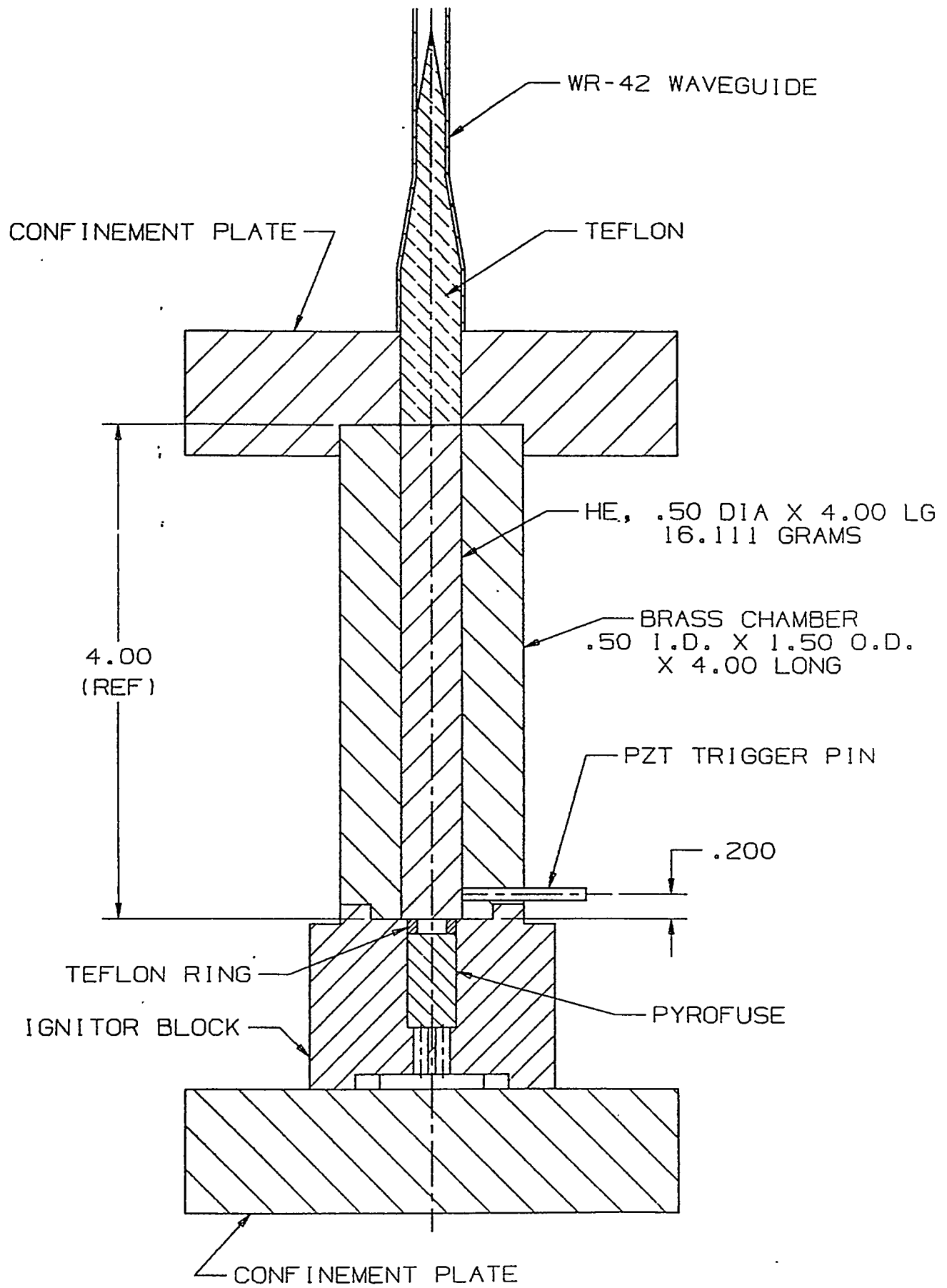

Fig. 3

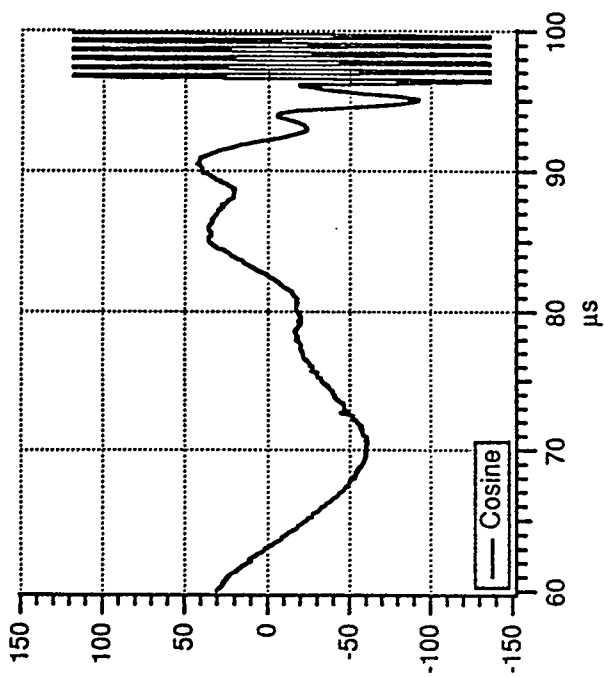

Fig. 4

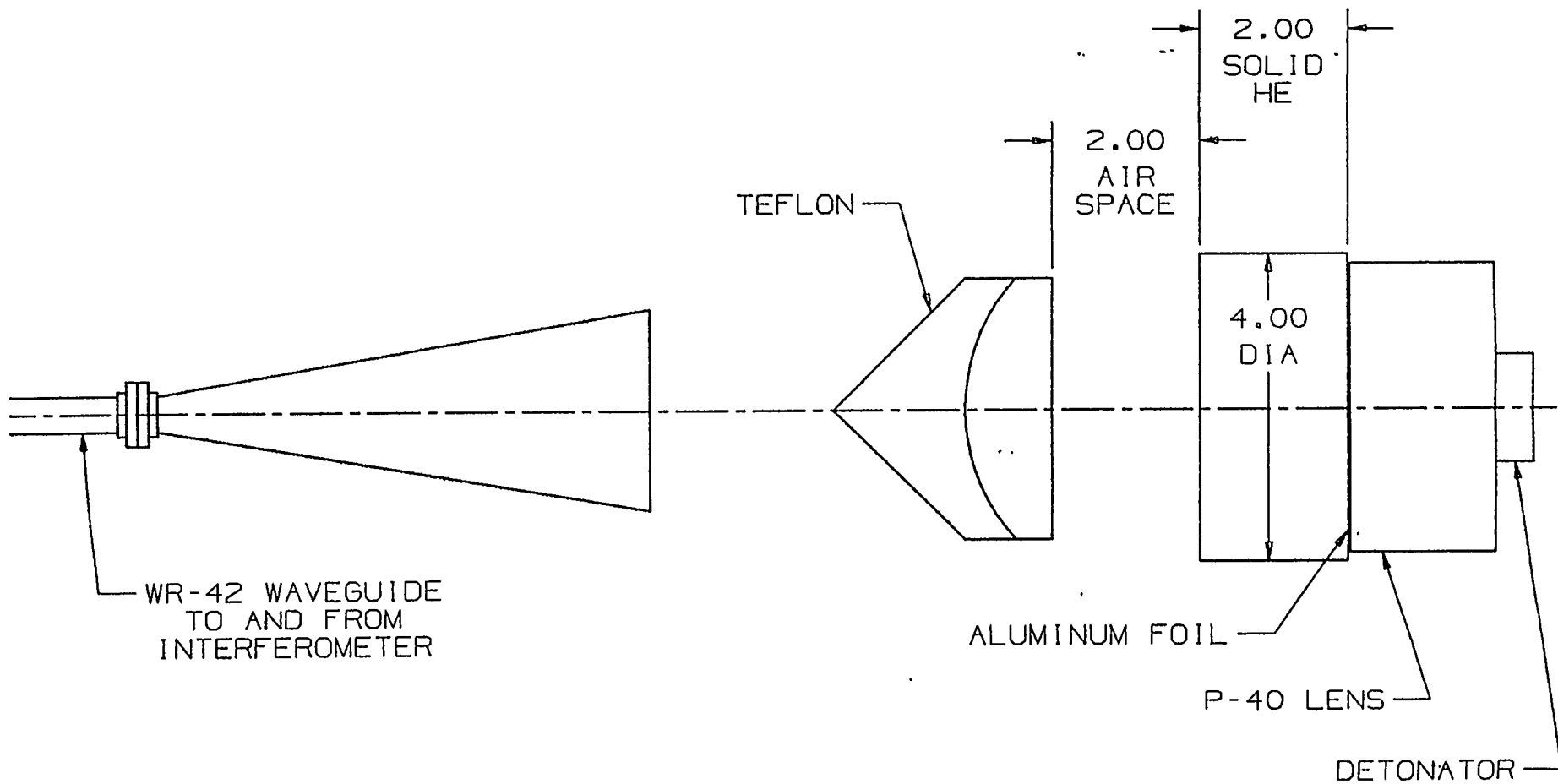

Fig 5

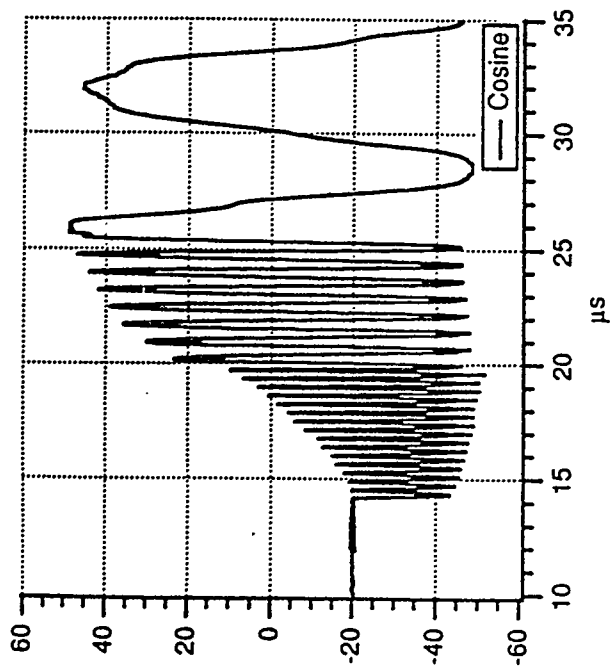

Fig. 6