

INCH-POUND

MIL-PRF-1/1588A  
16 July 1999  
SUPERSEDING  
MIL-E-1/1588(NAVY)  
3 February 1966

PERFORMANCE SPECIFICATION SHEET

ELECTRON TUBE, MAGNETRON  
TYPE 7417

This specification is approved for use by the Department of the Navy and is available for use by all Departments and Agencies of the Department of Defense.

The requirements for acquiring the electron tube described herein shall consist of this document and the latest issue of MIL-PRF-1.

**DESCRIPTION:** Magnetron, 10 kw (min), 5,500 to 5,600 MHz, fixed frequency, pulsed type, air-cooled, integral magnet, unipotential cathode.

**ABSOLUTE MAXIMUM RATINGS:**

Parameter: Unit:	ib a	Pi W	pi kw	Du ---	tpc μs
Maximum: Minimum:	8 ---	50 ---	50 ---	0.001 ---	1.0 0.15

**ABSOLUTE MAXIMUM RATINGS:**

Parameter: Unit:	Ef V	eb kv	epy kv	tk sec	VSWR ---	Anode T °C	Input Bushing Pressurization Psia
Maximum: Minimum:	7 --- 1/	8.2 ---	8 ---	180 ---	1.5:1 ---	100 --- 2/	45 13 3/

**PHYSICAL CHARACTERISTICS:**

Weight:	8 pounds, approximate.	Mounting position:	Vertical.
Input connection:	See figure 1.	Support:	See figure 1.
Output connection:	See figure 1.	Magnet isolation:	5/

**TEST CONDITIONS:** 4/

Parameter: Unit:	Ef V	ib A	tk sec	tp μs	Du ---	rrv kv/μs	epy kv	VSWR ---	F MHz
Maximum: Minimum:	6.3 --- 16/	4 --- 16/	180 ---	0.22 0.18	0.0003 ---	80 ---	7.8 7	1.1:1 ---	5,600 5,500

See footnotes at the end of table I.

**GENERAL:**

Qualification - Required. 13/

Section 5: Preparation for delivery.

## MIL-PRF-1/1588A

TABLE I. Testing and inspection.

Inspection	Method	Conditions	Acceptance Level	Inspection level or code	Symbol	Limits		Unit
						Min	Max	
<u>Qualification inspection</u>								
Anode-cathode capacity	4266		---	---	C	6	12	$\mu\mu\text{F}$
Temperature coefficient	4027	Anode temperature 40°C to 70°C <u>2/</u>	---	---	$\Delta\text{F}/\Delta\text{T}$	---	0.2	MHz/°C
Low temperature operation	1026	12/	---	---	T	-40	---	°C
High temperature operation	1026		---	---	T	+75	---	°C
Temperature rise	1075	Anode temperature TA = 25°C approx <u>2/</u>	---	---	T	+25	---	°C
<u>Conformance inspection, part 1 14/</u>								
Heater current	1301	Test 1	---	---	If	1.40	1.75	A
Standing wave ratio	4309	Test 1	---	---	---	---	---	---
Fix-tuned frequency	4218	Test 1	---	---	---	---	---	---
Heater-cathode warmup time	4303	Test 1	---	---	tk	---	180	sec
Pulse characteristics	4304	Test 1	---	---	---	---	---	---
Peak current	4304	Test 1	---	---	---	---	---	---
Pulse voltage	4306	Test 1	---	---	---	---	---	---
Power output	4250	Test 1	---	---	Po	3	---	W
Spectrum measurement	4308	ib = 3A to 8A <u>7/</u>	---	---	BW	---	14	MHz
Load stability	4315	VSWR 1.5:1; ib = 3A to 8A <u>9/ 10/</u>	---	---	Missing pulses	---	1	%
Starting stability	4315	Load stability conditions	---	---	Missing pulses	---	1	%

See footnotes at end of table.

TABLE I. Testing and inspection - Continued.

Inspection	Method	Conditions	Acceptance Level	Inspection level or code	Symbol	Limits		Unit
						Min	Max	
<u>Conformance inspection, part 2</u>								
Shock	---	G = 15 <u>15/</u>	---	---	---	---	---	---
Low frequency vibration	1031	No voltage	6.5	II	---	---	---	---
High frequency vibration	1031	No voltage	6.5	II	---	---	---	---
Non-oscillating characteristics	4309		---	---	---	---	---	---
Minimum VSWR	---		6.5	II	---	10:1	---	VSWR
Position of minimum VSWR	---	<u>6/</u>	6.5	II	dia	0.55	1.0	cm
Pulling factor	4310	<u>8/</u>	6.5	II	$\Delta F$	---	13	MHz
<u>Conformance inspection, part 3</u>								
Life test conditions	4.7	Test 1, group D ib = 5.5 A <u>11/</u>	---	---	t	500	---	hrs
Life test end points:	4.7.3							
Power output		Test 1	---	---	Po	2.4	---	W
Load stability	4315	VSWR = 1.5:1; ib = 3A to 8A <u>9/ 10/</u>	---	---	Missing pulses	---	2	%

- 1/ The maximum value specified herein is for non-oscillating condition. Heater surge current shall not exceed 4 amperes.
- 2/ The temperature shall be measured at the point indicated on figure 1.
- 3/ The gas used in pressurization shall provide insulating properties at least equal to that of clean, dry air at the pressures indicated herein.
- 4/ Unless otherwise specified herein, these conditions shall apply.
- 5/ In handling and mounting the magnetron, care shall be exercised to prevent demagnetization. A minimum distance of 4 inches (101.60 mm) shall be maintained between the tube and ferromagnetic materials or energized magnets.
- 6/ The plane containing the voltage standing wave minimum shall be within the limits specified herein when measured from reference plane D in the direction of reference plane B. The position of the minimum VSWR and the VSWR shall be determined at the operating frequency obtained during test 1.
- 7/ Stability will not be measured under this test. The RF bandwidth shall be within the limits specified when a VSWR of 1.5:1 is introduced in the load at a distance of approximately 0.25 meters from the magnetron coupling flange, the phase being adjusted for the widest spectrum.
- 8/ The pulling measurement shall be made in such a manner that thermal effects will not introduce appreciable errors.

TABLE I. Testing and inspection - Continued.

- 9/ No more than the percentage of pulses specified herein shall result in rf output pulses each having less than 70 percent of the energy contents of a normal pulse. The test shall be conducted for a period of 5 minutes, and satisfactory operation shall be obtained for each minute of this 5 minute period.
- 10/ Observations shall be made for load phase positions corresponding to maximum power and to minimum power.
- 11/ The tube shall pass all applicable conformance inspection, part I tests at the end of the life test specified herein except as modified under life test end points.
- 12/ The requirements of the starting stability test, with the exception of holding period, shall be the only criterion for this test.
- 13/ The activity responsible for the qualified products list is DSCC – Code VQE, Defense Supply Center Columbus, 3990 E. Broad Street, Columbus, OH 43216-5000 and information pertaining to qualification of products may be obtained from that activity. Application for Qualification tests shall be made by contacting DSCC – Code VQE.
- 14/ Conformance inspection, part 1, shall be a combined acceptance level (percent defective) of 1 percent and the inspection level shall be II.
- 15/ The magnetron shall be mounted on a test plate and dropped five times on each of three mutually perpendicular axes parallel to the reference planes shown on figure 1. The shock pulse shall have a duration of approximately 11 ms as measured at the quarter amplitude points of the acceleration shock wave. This is not a destructive test.
- 16/ The test shall be run with Ef set at 6.3 volts. The epy shall be adjusted to provide an ib of 4 amperes.
- 17/ Marginal notations are not used in this revision to identify changes with respect to the previous issue, due to the extensiveness of the changes.

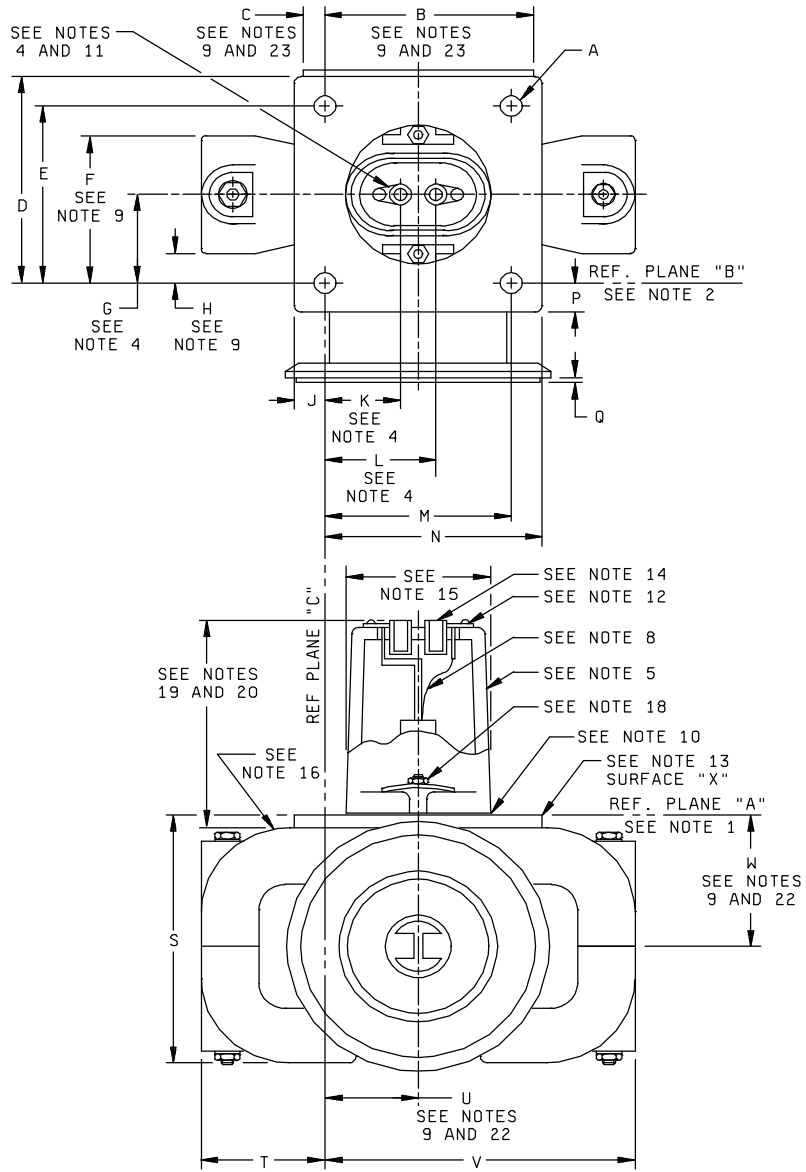

FIGURE 1. Outline drawing of electron tube type 7417.

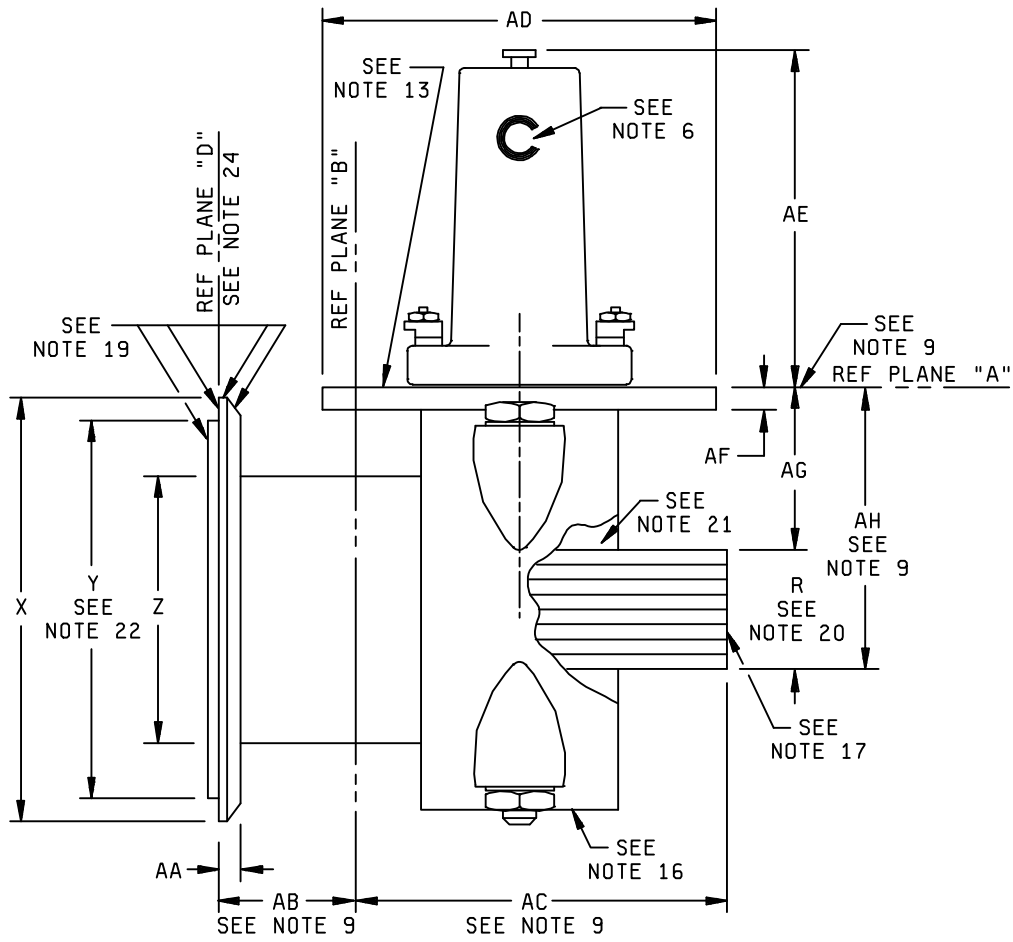

FIGURE 1. Outline drawing of electron tube type 7417 - Continued.

MIL-PRF-1/1588A

Ltr	Dimensions			
	Inches		Millimeters	
	Min	Max	Min	Max
Qualification inspection				
B	---	2.937	---	74.40
C	---	.312	---	8.19
D	---	3.025	---	86.83
E	2.610	2.640	66.29	67.06
F	---	2.437	---	61.90
G	1.302	1.322	33.07	33.58
H	.187	---	4.75	---
J	---	.400	---	10.16
P	---	.400	---	10.16
R	.839	.939	21.31	23.85
S	---	4.000	---	101.60
T	---	2.000	---	50.80
V	---	4.625	---	117.48
X	3.615	3.635	91.82	93.33
Y	3.308	3.316	84.02	84.23
Z	2.365	2.385	60.07	60.60
AA	.232	---	5.90	---
AC	3.177	3.197	80.50	81.20
AD	3.345	3.407	85.00	86.40
AE	2.940	2.960	74.60	75.20
AF	.187	---	4.75	---
AG	1.312	---	33.40	---
Conformance inspection, part 1				
Q	.027	.037	0.68	.094
U	1.280	1.344	32.50	34.17
W	1.843	1.907	46.80	48.40
AB	1.218	1.232	30.90	31.30
AH	---	2.562	---	65.00
Conformance inspection, part 2				
A	.340	.350	8.64	8.88
K	1.052	1.072	26.80	27.20
L	1.552	1.572	39.42	40.00
M	2.610	2.640	66.25	67.00
N	---	3.025	---	76.80

FIGURE 1. Outline drawing of electron tube type 7417 - Continued.

NOTES:

1. Reference plane "A" is defined as a plane passing along the face of the mounting plate.
2. Reference plane "B" is defined as a plane perpendicular to plane "A" passing through the center of the holes as shown.
3. Reference plane "C" is defined as a plane mutually perpendicular to planes "A" and "B" passing through the center of the hole as shown.
4. The jack holes shall be within a radius of .023 inch (0.58 mm) of the true location specified but shall be spaced .500 inch  $\pm$  .010 inch (12.70 mm  $\pm$  0.25 mm) with respect to each other. The centerlines of the holes shall be perpendicular to reference plane "A" within 3°0'.
5. Nylon, porcelain, or approved equivalent.
6. Indicate common cathode connected by letter "C".
7. Surface of plate extending beyond a 1.125 inch (28.58 mm) radius from the center of plate, shall be flat within .015 inch (0.38 mm).
8. Filament leads shall be flexible and slack.
9. Tolerance includes regular as well as lateral deviations.
10. .031 inch (0.78 mm) asbestos (or equivalent, preferred) gasket (optional).
11. Hex head banana pin .169 inch  $\pm$  .005 inch (4.29 mm  $\pm$  1.27 mm) diameter hole.
12. Leads soldered to terminals clips.
13. All solder joints on mounting plate and output section shall be such as to provide an hermetic seal at surface X.
14. Heater connection.
15. Any portion of the assembly extending above this surface shall be within a 1.109 inch (28.17 mm) radius of true center of plate.
16. Magnet with protective coating.
17. Radiator fins.
18. #6-32 elastic stop nut .312 inch (7.92 mm) across flats.
19. All areas except top of insulator to bottom edge of mounting plate, face, edge, and angle of flange shall be painted with black lacquer.
20. These dimensions apply to radiator size only.
21. Point at which temperature of tube is measured.
22. Refers to centerline of output flange as determined by 3.306 inch (83.97 mm) to 3.318 inch (84.28 mm) diameter.
23. Dimension applies to radiator.
24. Reference plane "D" is defined as a plane passing through the cutback section of the waveguide.

FIGURE 1. Outline drawing of electron tube type 7417 - Continued.



MIL-PRF-1/1588A

Custodians:

Navy - EC  
DLA - CC

Review activities:

Navy - AS, CG, MC

Preparing activity:

DLA - CC

(Project 5960-3547-05)