

INCH-POUND

MIL-PRF-1/1688B(USAF)
25 June 1999
SUPERSEDING
MIL-E-1/1688A(USAF)
24 January 1977

PERFORMANCE SPECIFICATION SHEET

ELECTRON TUBE, MAGNETRON
TYPE 8798

This specification is approved for use by the Department of the Air Force and is available for use by all Departments and Agencies of the Department of Defense.

The requirements for acquiring the electron tube described herein shall consist of this document and the latest issue of MIL-PRF-1.

DESCRIPTION: Pulsed, tunable frequency range 2.7 GHz to 2.9 GHz, rated peak power output 800 kW, external magnet, coaxial line output, forced-air cooled.

ABSOLUTE RATINGS:

Parameter:	Ef	epy	ib	Pi	pi	tp
Unit:	V	kv	a	W	kW	μsec
Maximum:	17	32	70	1,300	200	2.5
Minimum:	--- 1/	---	---	---	---	---
Parameter:	Du	tk	VSWR	Anode T	rrv	Alt.
Unit:	---	sec	---	°C	kV/μs	Ft
Maximum:	.0011	---	1.35	120	150	12,000
Minimum:	00	120	---	---	---	---

PHYSICAL CHARACTERISTICS:

Dimensions:	See outline drawing.
Weight:	6.5 pounds approximately.
Mounting position:	Any.
Cathode:	Unipotential.

TEST CONDITONS:

Parameter:	Ef	Magnetic field	tpc	Du	rrv	prr	tk
Unit:	V	H	μsec	---	kV/μs	---	sec
Test 1:	---	2,700	0.7	.0007	110	1,000	180
Test 2:	---	2,700	2.0	.0007	110	350	180
Test 3:	10	2,700	1.0	.001	150	1,050	---
Tolerance:	± 5% 1/	± 50 4/	± 0.1	---	---	---	---
Parameter:	tfc	trc	trv	VSWR	lb		
Unit:	μsec	μsec	μsec	---	mA dc		
Test 1:	0.50	0.125	0.15	1.15 max	46		
Test 2:	0.50	0.125	0.15	1.15 max	46		
Test 3:	0.50	0.125	0.15	1.35 max	39.5		
Tolerance:	± 0.10	± 0.045	± 0.05	---	± 5%		

See footnotes at end of table I.

GENERAL:

Qualification - Required.

AMSC N/A
DISTRIBUTION STATEMENT A. Approved for public release; distribution is unlimited.

MIL-PRF-1/1688B(USAF)

TABLE I. Testing and inspection.

Inspection	Method	Test	Conditions	Symbol	Limits		Unit
					Min	Max	
<u>Qualification inspection</u>							
High frequency vibration	1031	---	No voltages <u>Z</u> /	---	----	---	---
Temperature coefficient	4004	1	F1, F2, and F3 T = 60°C to 90°C	$\Delta F/\Delta T$	----	70	kHz/A
Low temperature	1026	---	tk = 180 sec	MP	---	1	%
<u>Conformance inspection, part 1</u>							
Dimensions	D-30(b)	---	See figure 1	---	---	---	---
Pressurizing	4003	---	$42.5 \pm 2.5 \text{ lb/in}^2$	---	----	---	---
Heater current nonoperating	4289	---	Ef = 16.0 V \pm 5 %; tk = 300 sec (min) <u>1</u> /	If	2.6	3.1	A
Pulse voltage	4306	1	F1, F3	epy	26	32	kv
Power output (1)	4250	1	F2, F3	Po	525	---	W
Power output (2)	4250	2	F1	Po	525	---	W
RF bandwidth	4308	1	F1, F2, F3	BW	---	2.5/tpc	MHz
Minor lobes	4308	1	F1, F2, F3	Ratio	8	---	dB
Stability	4315	1	F1, F2, F3	MP	---	0.5	%
Mechanical tuning range	4223	1	Low frequency	F1	---	2.7	GHz
		1	High frequency	F3	2.9	---	GHz
Power output (3)	4250	3	F1 and F3	Po	470	---	W
Stability	4315	2	<u>6</u> /	MP	---	0.5	%
<u>Conformance inspection, part 2</u>							
Pushing factor	4311	3	F2	Ratio	---	125	kHz/A
Pulling factor	4310	1	Ib = 28 mA dc to 46 mA dc; F2	F	---	15.0	MHz
Operating torque or force	4223	---	<u>8</u> /	Torque	---	20	ounce-inch
Dimensions	D-30(b)	---	See figure 1	---	---	---	---

See footnotes at end of table.

TABLE I. Testing and inspection - Continued.

Inspection	Method	Test	Conditions	Symbol	Limits		Unit
					Min	Max	
<u>Conformance inspection, part 3</u>							
Life test	---	1	Group S; F2	t	1,000	---	hrs
Life test end points:	---						
Power output	4250	1	F1, F2, and F3	Po	420	---	W
RF bandwidth	4308	1	F1, F2, and F3	BW	---	3.0/tpc	MHz
Stability	4315	1	F1, F2, and F3	MP	---	1.0	%
Minor lobes	4308	1	F1, F2, and F3	Ratio	7	---	dB

1/ Standby or preheat heater voltage shall be 16.0 V dc \pm 5 percent. During high voltage operation, heater voltage should be adjusted to the following approximate values:

<u>Pi (watts)</u>	<u>Ef (V dc)</u>
1,200-1,400	5.5
1,000-1,200	8
800-1,000	10.5
600-800	13
400-600	15
0-400	16

2/ These periodic check tests which have been performed and have met specified requirements within 36 months need not be performed if test requirements, material, or manufacturing processes have not changed in the interim.

3/ The value of VSWR specified excludes the tube coupling adapter.

4/ The magnetic field should be calibrated in accordance with the following procedure. See figure 2.

- a. With conventional 1/8 inch pole piece attached to the pole face of the magnet opposite the magnetron tuner, the magnetic gap should be 1.800 inches.
- b. The magnetic field should then be adjusted for 2,700 gauss at the center of the gap.
- c. Remove the conventional 1/8 inch pole piece and replace it with the distortion pole piece.

5/ Frequency definitions:

F1 = 2.7 GHz F2 = 2.8 GHz F3 = 219 GHz

6/ Missing pulses shall be counted during the last three minutes of a stability test interval not to exceed 6 minutes. The stability test interval shall first be conducted at F1 and shall be started no later than 10 minutes after the application of high voltage. Test intervals shall then be conducted consecutively at F2 and F3.

7/ Following this test, the magnetron shall be capable of normal operation under test condition 1.

8/ Tuning mechanism will provide full range of tuning with five 360° turns, maximum.

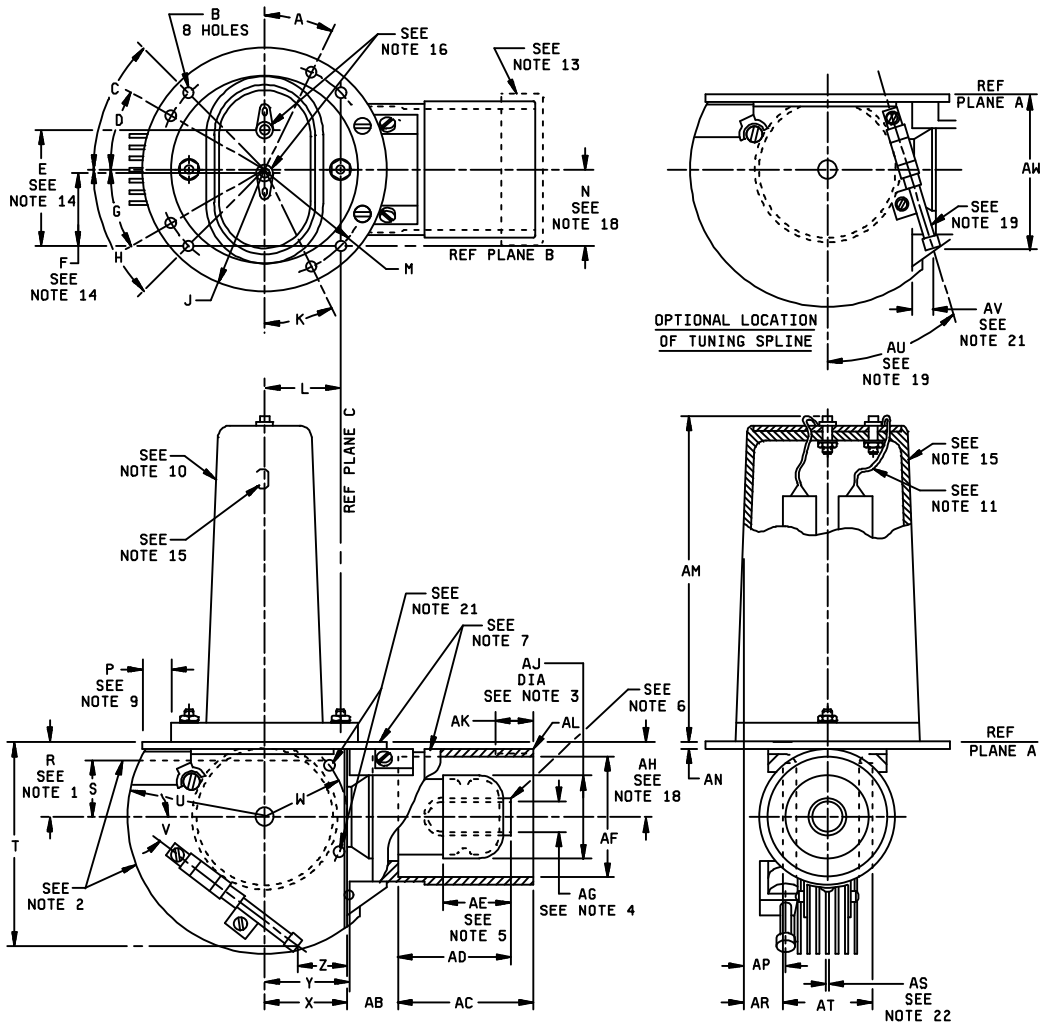

FIGURE 1. Outline drawing of electron tube type 8798.

MIL-PRF-1/1688B(USAF)

OUTLINE DIMENSIONS SIMILAR TO 242-JAN (REF)

Ltr	Dimensions				Ltr	Dimensions			
	Inches		Millimeters			Inches		Millimeters	
	Min	Max	Min	Max		Min	Max	Min	Max
Conformance inspection, part 1					Conformance inspection, part 2				
E	---	2.156 Nom	---	54.76 Nom	AU	11°30'	16°30'	11°30'	16°30'
F	---	1.359 Nom	---	34.52 Nom	AV	---	.313 Nom	---	7.95 Nom
L	---	1.437 Nom	---	36.50 Nom	AW	---	2.812 Nom	---	71.42 Nom
N	1.417	1.457	36.00	37.01	A	29°48'	30°12'	29°48'	30°12'
R	---	1.440 Nom	---	36.58 Nom	B	.205	.215	5.21	5.46
T	---	3.500 Nom	---	88.90 Nom	C	44°48'	45°12'	44°48'	45°12'
X	---	1.437 Nom	---	36.50 Nom	D	29°48'	30°12'	29°48'	30°12'
Z	---	.756 Nom	---	19.20 Nom	G	29°48'	30°12'	29°48'	30°12'
AC	2.287	2.307	58.09	58.60	H	44°48'	45°12'	44°48'	45°12'
AD	2.060	2.110	52.32	53.59	J	2.266 R	2.296R	57.56 R	58.32 R
AE	1.125	---	28.57	---	K	29°48'	30°12'	29°48'	30°12'
AF	2.314	2.328	58.77	56.84	M	2.029 R	2.035 R	51.54 R	51.69 R
AG	.550	.560	13.97	14.22	P	.500	---	12.70	---
AH	1.420	1.460	36.07	37.08	S	1.063	---	27.00	---
AJ	---	1.620	---	41.15	U	---	2.656R	---	67.46 R
AL	2 1/2-18 NS-2A		2 1/2-18 NS-2A		V	30°	35°	30°	35°
AN	---	.187 Nom	---	4.75 Nom	W	1.500 R	---	38.10 R	---
AP	.438	.688	11.12	17.47	Y	1.500	---	38.10	---
AR	.525	.625	13.33	15.87	AB	.803	.833	20.40	21.16
AS	---	.025 Nom	---	0.64 Nom	AK	.593	---	15.06	---
AT	---	1.740	---	44.20	AM	6.219	6.407	157.96	162.74

NOTES: (MECHANICAL REQUIREMENTS)

1. The periphery of the anode shall lie within a 2.160 inch (54.86 mm) diameter circle located as specified for non-tunable side of anode.
2. Maximum width specified applies to area defined by broken line and circumference of radiator.
3. Center-line of maximum diameter shall be concentric with center-line of guard pipe to within 0.040 inch (1.02 mm).
4. Applies to inner conductor insert only center-line of inner conductor insert shall be concentric with center of guard pipe to within 0.025 inch (0.64 mm).
5. Applies to straight portion of inner conductor wall.
6. No sharp edges of outside diameter at end of inner conductor.
7. Tube may be supported by plate (mounting) or guard pipe.
8. Spline for adjusting tuning mechanism is as follows: 12 teeth 48 pitch - 0.250 inch (6.35 mm) pitch diameter.
9. This annular area shall be flat within 0.015 inch (0.38 mm) (a thickness gauge 0.125 inch (3.18 mm) wide shall not enter more than 0.250 inch (6.35 mm)).
10. Pyrex glass or approved equivalent.
11. Leads shall be flexible and slack.
12. Tuning mechanism will provide full range of tuning with five 360° turns, maximum.
13. Protective guard for shipping purposes.
14. The center of the jack holes shall be within a radius of 0.100 inch (2.54 mm) of the location specified but shall be spaced 0.797 inch (20.24 mm) ± 0.015 inch (0.38 mm) with respect to each other.
15. Common cathode connection marked with letter "C":
16. Hex locking head banana pin jack 0.594 inch (15.09 mm) long, hole 0.169 inch (4.29 mm) ± 0.005 inch (0.13 mm).

MIL-PRF-1/1688B(USAF)

17. Paint with heat-resistant non-corrosive paint; the following shall be free from paint-top surface of mounting plate parts above mounting plate, screw threads on guard pipe and all surfaces inside guard pipe, tuning gear, stop assembly, and worm shaft assembly.
18. Applies to location of center of guard pipe only.
19. Clearance to adapter guard pipe must be sufficient to allow use of S. S. White Co. No. 2666X end fitting (13/32 diameter).
20. All solder joints on mounting plate and guard pipe shall be soldered to provide an hermetic seal.
21. Optical location of tuning spline, tube to be supplied with spline located as specified by customer.
22. This dimension shows relation between a plane passing through lateral center of anode and a plane through center of guard pipe.
23. Reference plane "A" is defined as a plane passing along the face of the mounting plate.
24. Reference plane "B" is defined as a plane perpendicular to plane "A" passing through the center of the holes as shown.
25. Reference plane "C" is defined as a plane mutually perpendicular to planes "A" and "B" passing through the center of the hole as shown.
26. The letter "A" has been added to indicate external thread, not unified thread.

MIL-PRF-1/1688B(USAF)

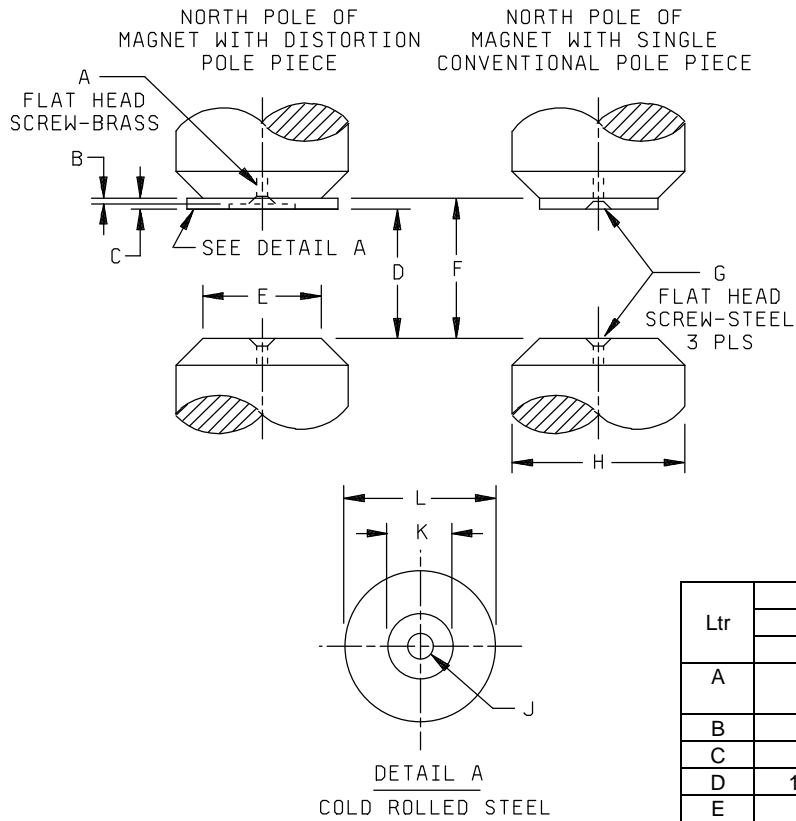

Ltr	Dimensions			
	Inches		Millimeters	
	Min	Max	Min	Max
A	#10-32 flat head screw-brass		#10-32 flat head screw-brass	
B	---	.03	---	0.8
C	.125 REF		3.18 REF	
D	1.795	1.805	45.59	45.85
E	1.63 (TYP) DIA		41.40 (TYP) DIA	
F	1.920	1.930	48.77	49.02
G	#10-32 Flat head screw-steel (3 places)		#10-32 Flat head screw-steel (3 places)	
H	2.25 (TYP) DIA		57.15 (TYP) DIA	
J	.312 DIA Hole CSK		7.92 DIA Hole CSK	
K	---	.786	---	19.96
L	---	2.000	---	50.80

NOTE: Dimensions are in inches. Metric equivalent values are provided for information only and is based upon 1 in. = 25.4 mm. Unless otherwise specified, tolerances are ± 0.03 .

FIGURE 2. Magnetic field calibrators for electron tube type 8798.

MIL-PRF-1/1688B(USAF)

Custodians:
Air Force - 11
DLA - CC

Preparing activity:
DLA - CC

Review activities:
Air Force - 99

(Project 5960-F239)