

FURUNO 1715 SERVICE MANUAL



Quick Links

[Display Unit](#)

[Scanner Unit](#)

[Replacement of Major Parts in Scanner Unit](#)

[Magnetron](#)

[Troubleshooting Matrix Table](#)

[Chapter 5 Troubleshooting](#)

Table of Contents

[Table of Contents](#)

[General](#)

[Display unit](#)

[Scanner unit](#)

[Display unit](#)

[Scanner unit](#)

[Display unit](#)

[Scanner unit](#)

[Removing display unit cover](#)

[Replacement of Major Parts in Display unit](#)

[DU board](#)

[LCD unit](#)

[PNL board](#)

[Replacement of Major Parts in Scanner unit](#)

[Synchronous Belt and Motor](#)

[Magnetron](#)

[MIC](#)

[Program updating](#)

[Error Messages](#)

[Troubleshooting Matrix table](#)

[Self Test](#)

[Display unit](#)

[Scanner unit](#)

[Test points on each board](#)

[DU board \(03P9320\)](#)

[MD board \(03P9270\)](#)

[INT board \(03P9322\)](#)

[STC waveform](#)

[Other ManualsLib Projects](#)

FURUNO

SERVICE MANUAL

MARINE RADAR

MODEL MODEL 1715



FURUNO ELECTRIC CO., LTD.
NISHINOMIYA, JAPAN

PRINTED IN JAPAN

© **FURUNO ELECTRIC CO., LTD.**

9-52 Ashihara-cho,
Nishinomiya, Japan

Telephone : 0798-65-2111
fax : 0798-65-4200

Your Local Agent/Dealer

All rights reserved.

Printed in Japan

FIRST EDITION : SEP. 2003

PUB.No. SME-35140-A

(KAOK) MODEL1715



00014876000



SME35140A00

Chapter 1 Circuit Description

1.1 General.....	1
1.2 Display unit.....	2
1.3 Scanner unit	6

Chapter 2 Location of Parts

2.1 Display unit.....	10
2.2 Scanner unit	11

Chapter 3 Adjustment

3.1 Display unit.....	13
3.2 Scanner unit	13

Chapter 4 Maintenance

4.1 Removing display unit cover	14
4.2 Replacement of Major Parts in Display unit.....	15
(1) DU board.....	15
(2) LCD unit	15
(3) PNL board.....	15
4.3 Replacement of Major Parts in Scanner unit	16
4.4 Synchronous Belt and Motor	17
4.5 Magnetron.....	18
4.6 MIC.....	18
4.7 Program updating	19

Chapter 5 Troubleshooting

5.1 Error Messages	22
5.2 Troubleshooting Matrix table.....	22

5.3 Self Test24

 5.3.1 Display unit.....24

 5.3.2 Scanner unit27

5.4 Test points on each board28

 1) DU board (03P9320)28

 2) MD board (03P9270)28

 3) INT board (03P9322)29

 4) STC waveform29

Exploded View D-1

Electrical Parts List E-1

Schematic Diagrams S-1

Chapter 1 Circuit Description

1.1 General

The CPUs in the display and scanner units communicate each other via RS-422 interface. The control data, such as Gain, STC and tuning data, is sent from the display unit to the scanner unit in serial.

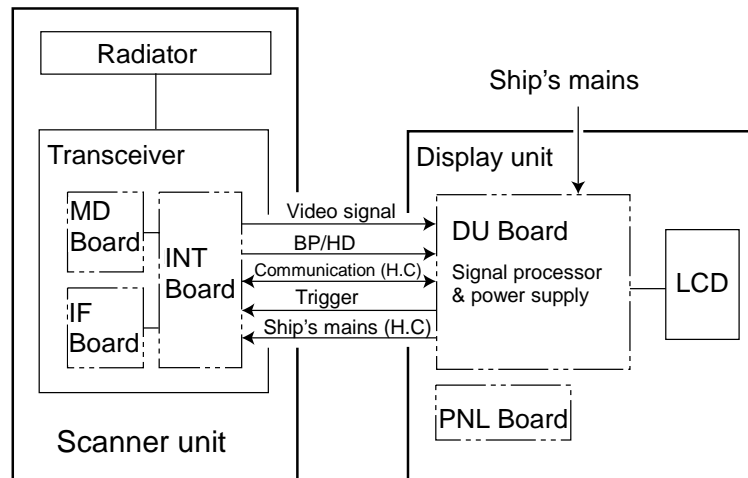

Fig.1-1 Simplified Block Diagram

The trigger pulse is generated on DU board in the display unit and sent to the modulator on MD board in the scanner unit. The modulated signal triggers the magnetron and high frequency pulses are transmitted from the radiator. The target echo received by the radiator is frequency-converted by the MIC. 60 MHz IF signal is amplified in the scanner unit and then sent to the display unit. DU board in the display unit processes video signal to show target echoes on the LCD display.

Bearing pulse (BP) and heading signal (HD) are also delivered to the display unit from the scanner unit.

1.2 Display unit

TX trigger pulse is generated by gate array, U79 and sent to the scanner unit. The video signal from the scanner unit is A/D converted and sampled by gate array, U78. Echoes in each sweep are stored on the V-RAM via gate array, U79. Upon receiving the heading pulse, the stored data are output to the LCD in four gradations, according to echo strength.

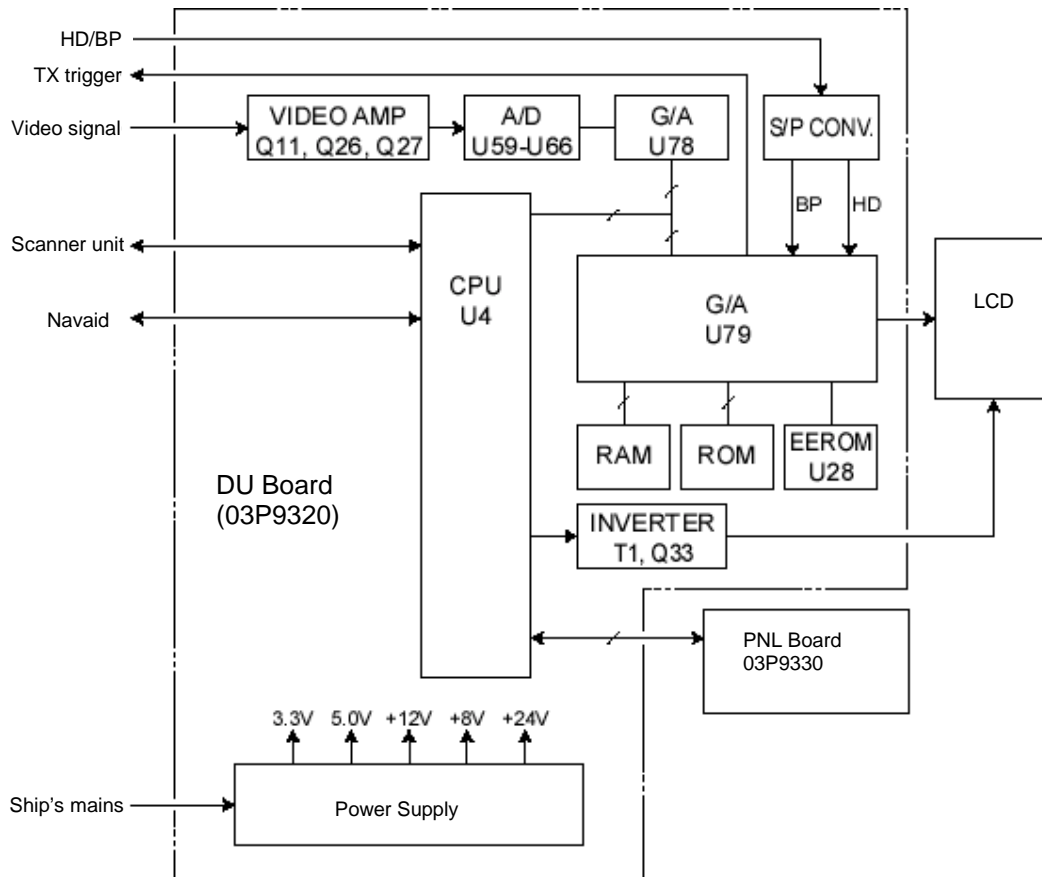

Fig.1-2 Block Diagram of Display Unit

The display unit consists of PNL board (03P9356), DU board (03P9320) and LCD unit (EW50300FDWR). Each board functions as below.

PNL Board (03P9356)

This board functions as a man-machine interface, equipped with keys, LEDs for panel-illumination, and a buzzer.

DU Board (03P9320)

According to the range setting, gate array U79 generates TX trigger pulses in specified pulse repetition rate. Reference oscillator output is divided by the data from the CPU to decide the PRR.

The pulse repetition rates differs slightly from set to set to prevent the radar interference.

The video signal from the scanner unit inputs to the video circuit on the DU board.

The video circuit includes FTC circuit that rejects the reflecting signals from the rain and snow. CPU switches on or off the FTC according to control panel setting.

The video signal is converted by the A/D converter into seven-level digital signal, and input to the radar signal processing circuit in the gate array U78. The digital video signal is sampled in U78 with the sampling clock corresponding to the range setting. Further, when the interference rejecter is turned on, each video signal is correlated with the corresponding transmission to eliminate or reduce the radar interference signals. The processed video signal by U78 is written into VRAMs via U79 for indication.

The bearing signal and heading signal are input to serial-to-parallel converter and then applied to G/A U79 individually. Heading error obtained at heading alignment in installation menu is stored in EEPROM U28, and used by CPU to calculate the correct antenna direction. TX time delay data is also stored in EEPROM U28.

Unlike R/ θ coordinate sweep, LCD display employs X-Y coordinate method similar to so called TV- sweep method. U79 converts the R/ θ video signal to X-Y coordinates using formulas, $RSIN \theta$ and $RCOS \theta$. The coordinate-converted video signal is written and maintained onto VRAM for trail indication.

The data writing/reading onto/from the VRAM is carried out by U79 in time sharing. U79 retrieves data from VRAM to display it on the LCD display.

Scanner unit control data is converted to serial data by RS-422 interface, U27 and sent to the scanner unit through a balanced RS-422 line. The control data includes transmission on/off, TX pulsewidth selection, Gain and STC signals.

The data from the navigational aid is received through photo-couplers U10 and U11.

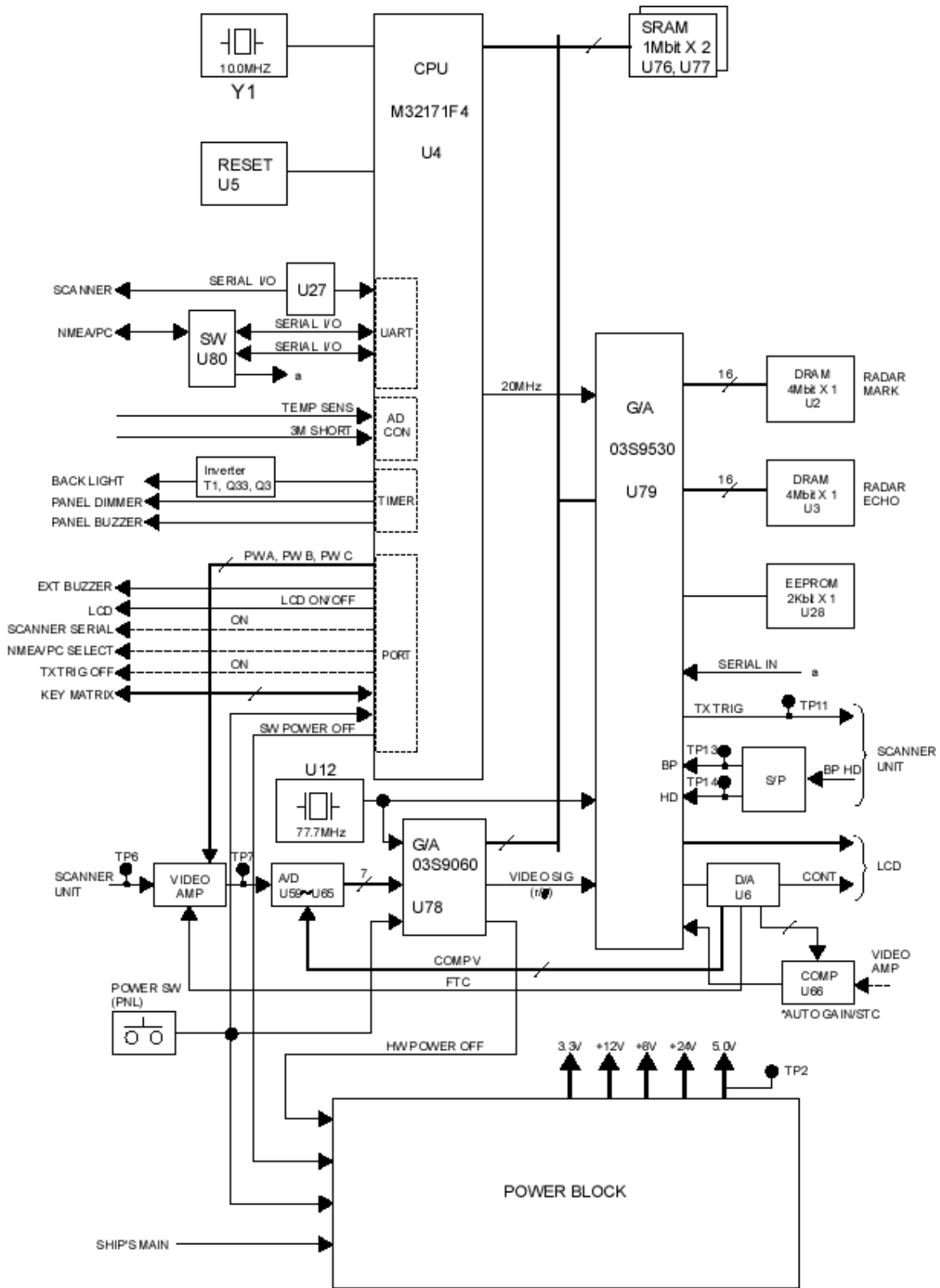

Fig.1-3 Block Diagram of DU Board (03P9320)

The unit operates on universal voltage ranging from 10.8 V to 31.2 V DC. This range covers the voltage requirement for 12 V/24 V ship's mains 10 % lower and 30 % higher. The ship's mains is supplied through a noise filter to the pulsewidth-controlled DC-DC converter which generates the stable voltages; +5 V, +12 V, +8 V and -24 V. The ship's mains is also supplied to the scanner unit, bypassing the power supply circuit in the display unit. +5 V is mainly used for the digital circuits, +12 V for the video circuits, +8 V for the backlight, and -24 V for the LCD display. The DC-AC inverter consisting of Q33, Q34 and T1 generates 210 V AC for the backlighting of the LCD display.

If the power supply is connected to the radar in reverse polarity, the reverse-polarity protector activates so that the fuse is blown off to prevent the damage to the unit.

The power supply circuit contains low- and high-input voltage protector.

1.3 Scanner unit

In the scanner unit, the TX trigger from the display unit is modulated to use it for triggering the magnetron. The received echo is fed to the MIC and down-converted to 60 MHz IF signal. Auto-gain and auto-STC circuits are not in the scanner unit, but in the display unit.

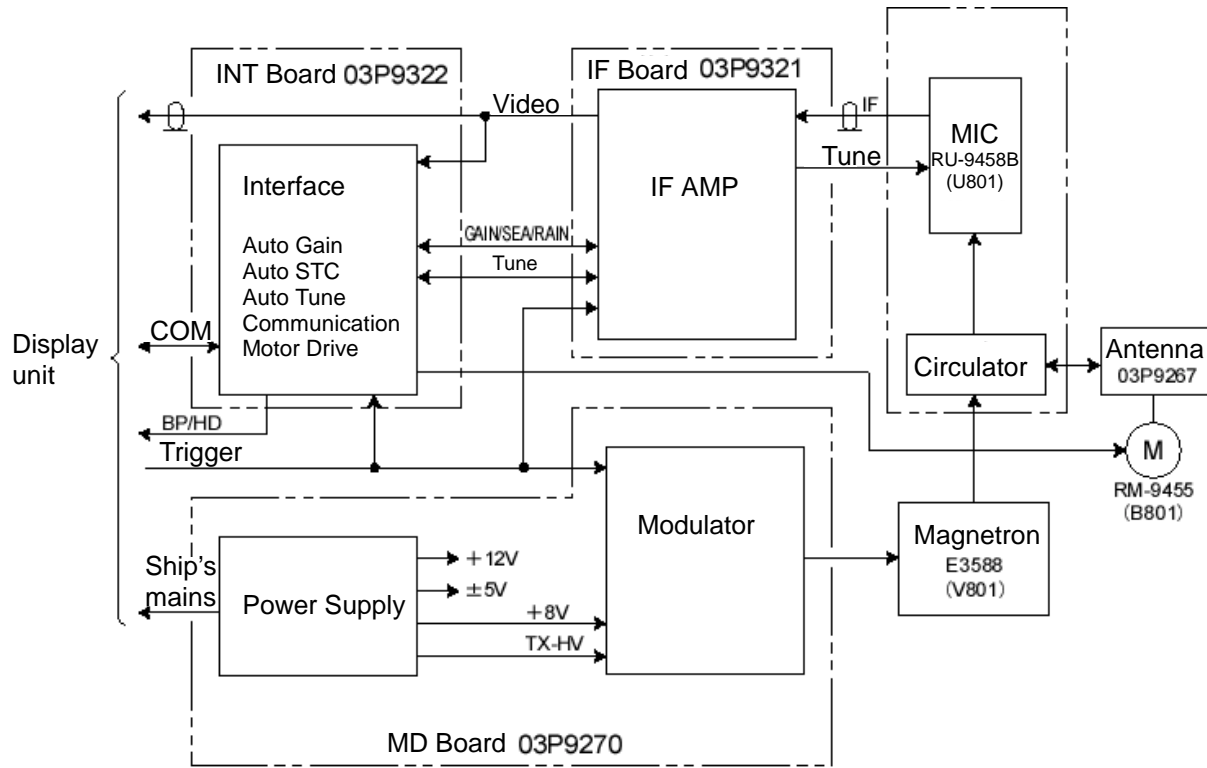

Fig.1-4 Block Diagram of Scanner Unit

INT board (03P9322)

INT board mainly consists of CPU U4 that includes the RAM, ROM and analog ports, RS-422 interface U5, a motor drive circuit and a gain control signal generator.

CPU U4 receives control panel settings on the display unit through the RS422 interface U5. The D/A converter U2 converts Gain, A/C RAIN, and tuning control signals from digital to analog. A/C SEA and A/C RAIN circuit consisting of Q1, Q2 and Q3 outputs GAIN CONT signal to IF board.

The CPU U4 controls the stepping motor drive circuit, Q4 to Q7 to keep the antenna rotation speed constant.

The heading signal (HD) from the lead switch is mixed with the bearing pulse (BP) by Q9 to Q11 and sent to the display unit.

The ship's main is supplied to the power supply circuit on the MD board via INT board. MD board generates +5 V, +12 V and -6 V for the use on INT board.

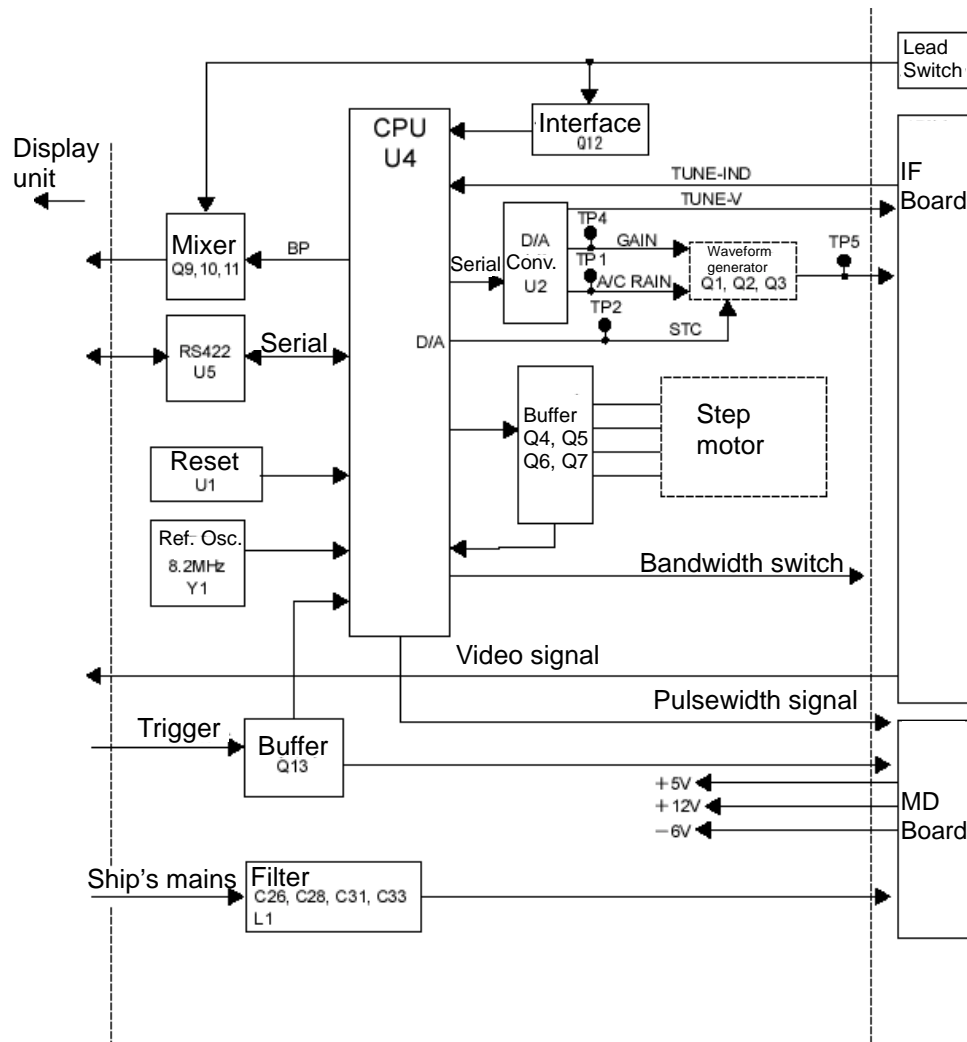

Fig.1-5 Block Diagram of INT Board (03P9322)

IF Amplifier board (03P9321)

The 60 MHz IF amplifier consists of Q1, Q2, U1 and U2, and provides the bandwidth of 7 MHz. The tuning level detector, U3 to U8, detects the main bangs to indicate the tuning level.

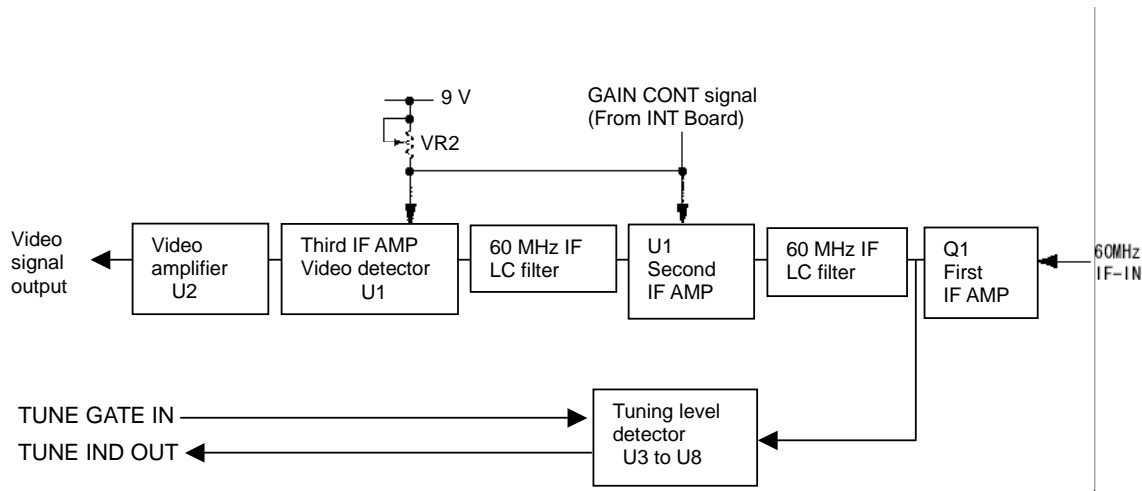

Fig.1-6 Block Diagram of IF AMP Board (03P9321)

MIC (RU-9458B)

The circulator in the module switches between the transmitting and receiving microwave circuits so that the transmitting radio energy is efficiently transmitted to the antenna without leaking to the receiver side and the receiving radar signal from the antenna is sent with efficiency to the receiver without leaking to the transmitter side.

The receiver circuit consists of a diode limiter, an RF amplifier, a balanced mixer and an FET oscillator. The diode limiter protects the amplifier and balanced mixer from the excessive input power. The mixer converts the input microwave signal to the 60 MHz IF signal. The oscillator is voltage-controlled and outputs the signal to the mixer.

MD board (03P9270)

The MD board consists of a power supply circuit and a modulator.

There are two DC-DC converters in the power supply circuit: one generates -6 V, $+5$ V, and $+12$ V and the other magnetron heater voltage and TX HV. In the DC-DC converter, drivers Q803 and Q832 are driven by PWM controllers, U801 and U805 respectively.

The magnetron current, -6 V, $+5$ V, $+12$ V, $+8$ V (magnetron heater voltage), and TXHV can be measured at the test point TP804.

The modulator in TX circuit receives the transmitting pulsewidth selection signals, PL-A and PL-B, from INT board, and the trigger signal from the display unit. One-shot multivibrator U851 generates the transmitting trigger pulse of which the pulsewidth depends on range setting. VR851 and VR852 adjust the output power of the magnetron. The pulse is boosted up by T851 and applied to the magnetron.

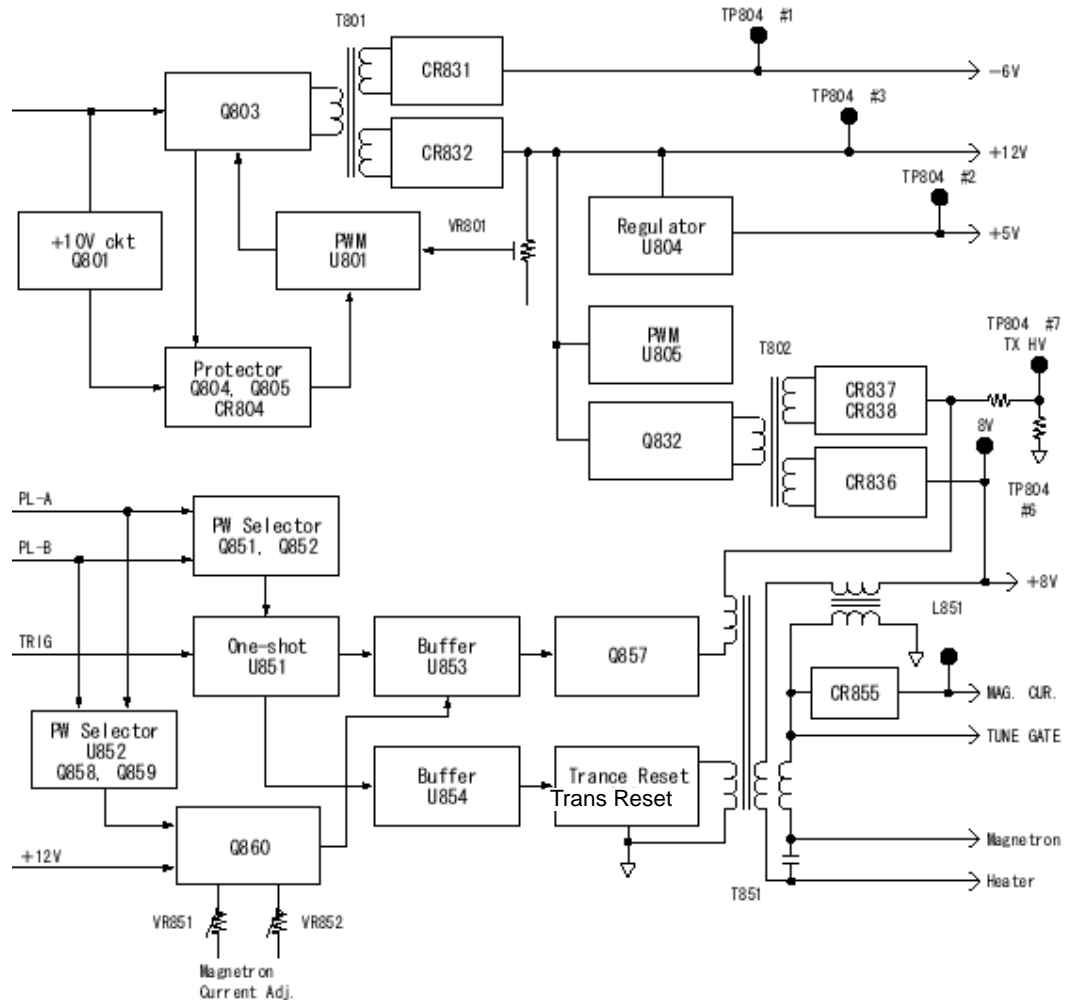

Fig.1-7 Block Diagram of MD board (03P9270)

Chapter 2 Location of Parts

2.1 Display unit

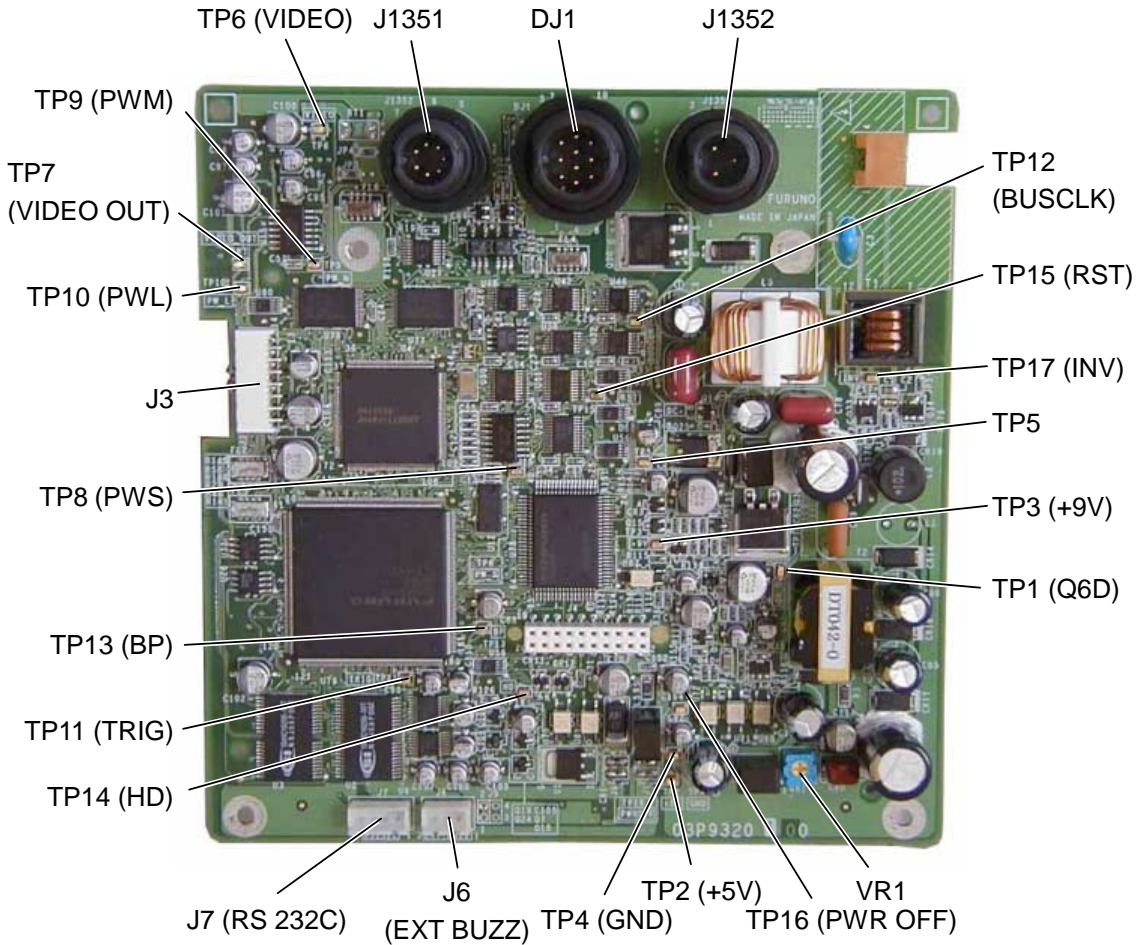

Fig.2-1 DU board (03P9320)

2.2 Scanner unit

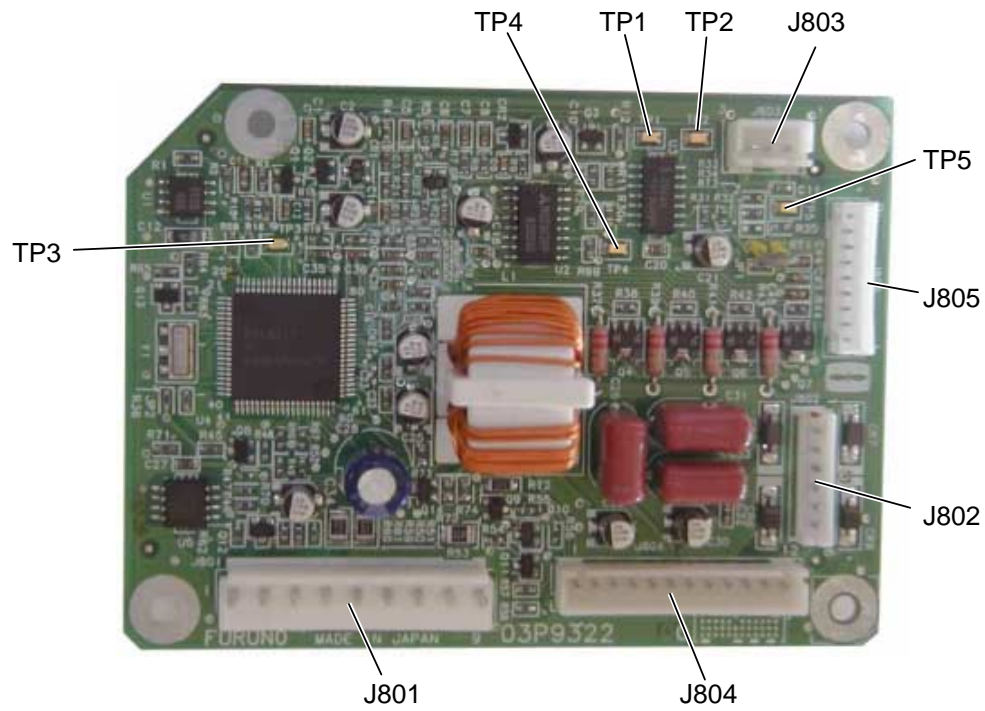

Fig.2-2 INT board (03P9322)

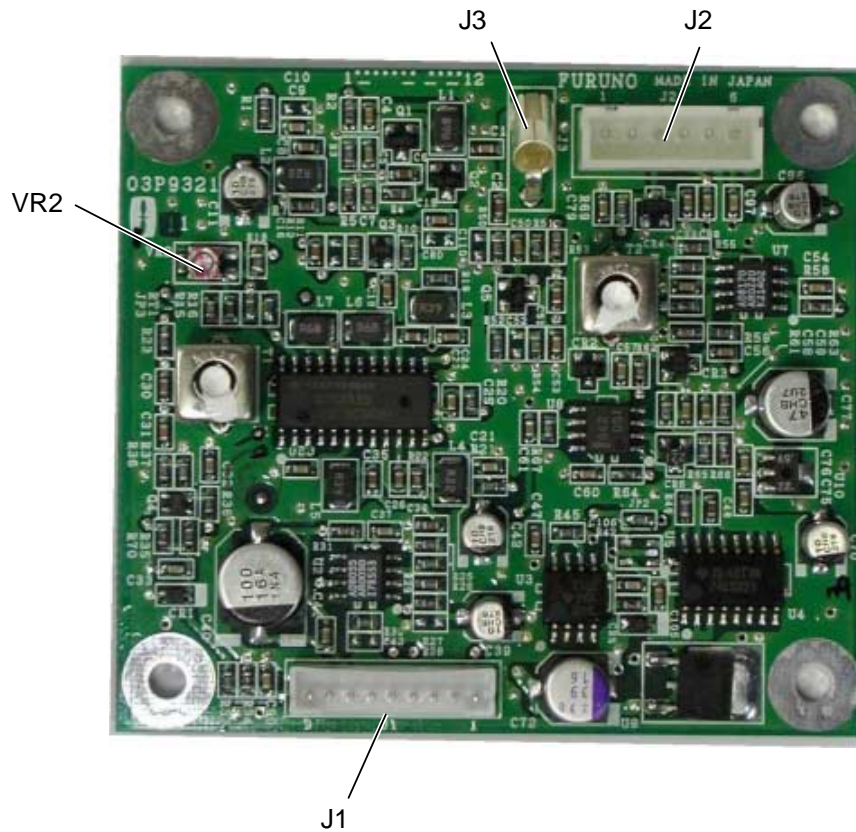

Fig.2-3 IF board (03P9321)

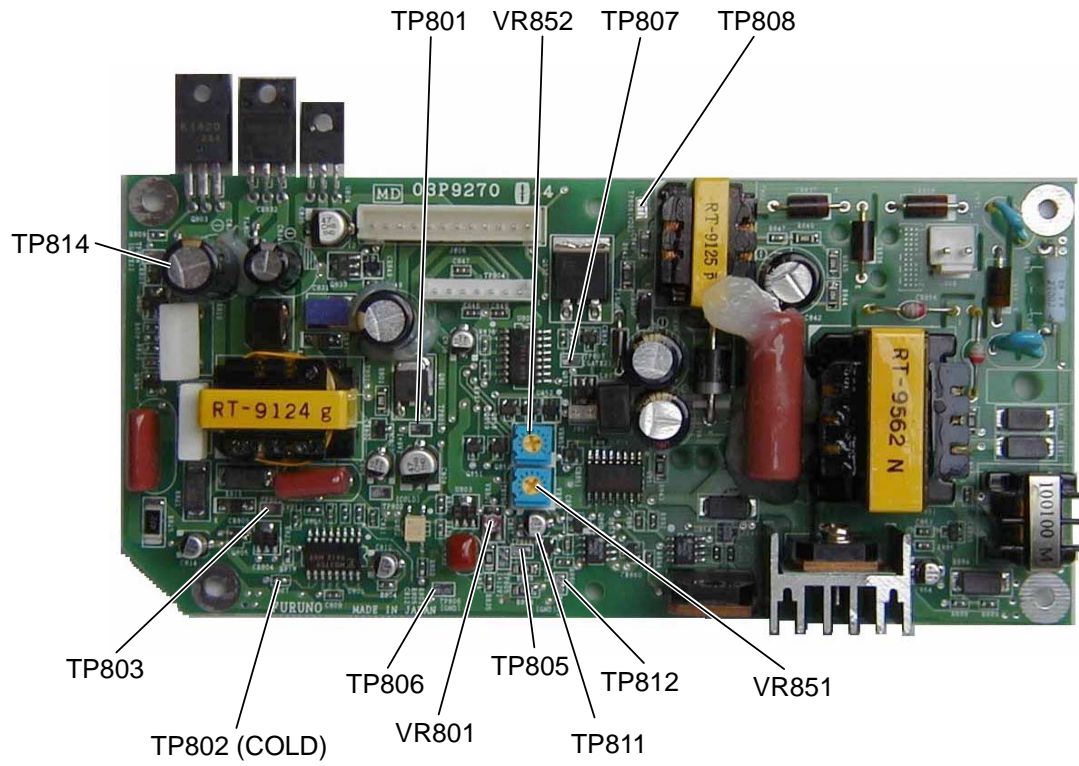

Fig.2-4 MD board (03P9270)

Chapter 3 Adjustment

DANGER- High voltage

The display unit contains 1 kVAC for LCD backlighting and the scanner unit 300 VDC for TX.

3.1 Display unit

+5 V is adjusted by VR1 on DU board. See Fig.3-1 for the location of parts.

Table 3-1 Test points of Display unit

Item	Setting	Test point	Ratings	Adjuster
+5 V	TX (8 NM)	TP4 (+), TP5 (-)	4.95 to 5.05 Vdc	VR1
+12 V	ST-BY	J1#7 (+), J1#5 (-)	11.2 to 12.4 Vdc	
-22 V	ST-BY	J1#10 (+), J1#5 (-)	-22.9 to -20.7 Vdc	
-6 V	ST-BY	J1#9 (+), J1#5 (-)	-6.0 to -5.0 Vdc	

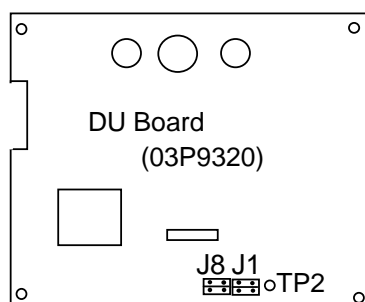

Fig.3-1 Location of J1 and J8 on DU board

3.2 Scanner unit

Adjusters on MD board in the scanner unit are adjusted as below.

Table 3-2 Test points of Scanner unit

Item	Setting	Test point	Rating		Adjuster
+12 V	ST-BY	TP804#3 (+) TP804#4 (-)	11.9 to 12.1 Vdc		VR801
+8 V heater volt.	ST-BY	TP804#6 (+) TP804#4 (-)	7.8 to 8.2 Vdc		
TX-HV (divided)	ST-BY	TP804#7 (+) TP804#4 (-)	8.5 to 9.35 V		
Magnetron current	TX	TP804#5 (+) TP804#4 (-)	Long	3.05 to 3.15 V	VR851
			Short	3.35 to 3.45 V	VR852

Chapter 4 Maintenance

This unit is designed for board level maintenance. Thus, component replacement is not recommended.

4.1 Removing display unit cover

To remove the display unit cover:

1. Remove three connector nuts on the display unit cover.
2. Remove six screws fixing the display unit cover to the front panel.
3. Find a slot at both sides of the unit. (Fig.4-2) The display unit cover has locking mechanism.
4. Insert a coin into the slot on the left side of the display unit. Giving a little bit of force, separate the cover. Do the same at the right side.
5. When replacing the cover, confirm that the connector packing is seated in position.



Fig. 4-1 Display Unit, Rear View



Fig. 4-2

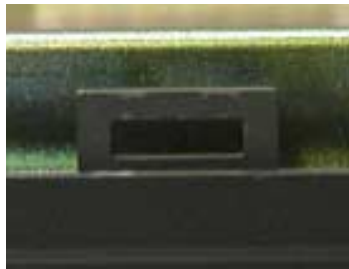
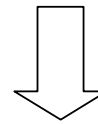

(a) Hole for locking tab on the front panel



(b) Locking protrusion on the cover

4.2 Replacement of Major Parts in Display unit

(1) DU board

To remove DU board;

1. Disconnect the FPC and the LCD lamp connector.
2. To remove DU board, loosen four screws ringed in Fig.4-3.
3. Pull DU board up straightly.

(2) LCD unit

To remove LCD unit;

4. Loosen three screws ringed in Fig.4-4.
5. Remove the LCD unit together with the mounting plate.
6. Separate the LCD unit from the mounting plate by loosening a screw at each corner.

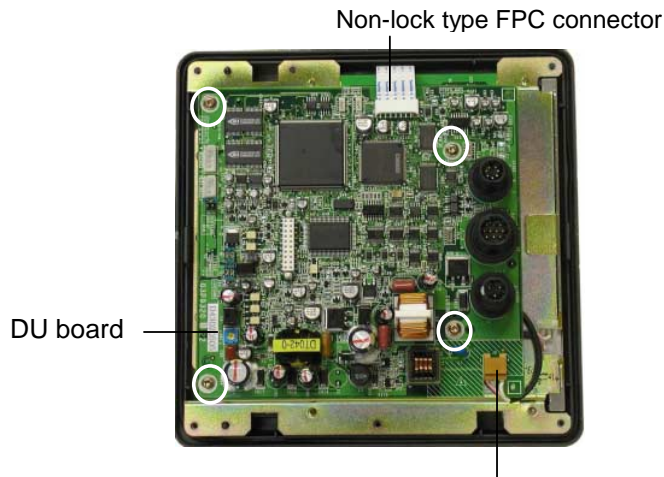

Fig. 4-3

LCD lamp connector

HIGH VOLTAGE!

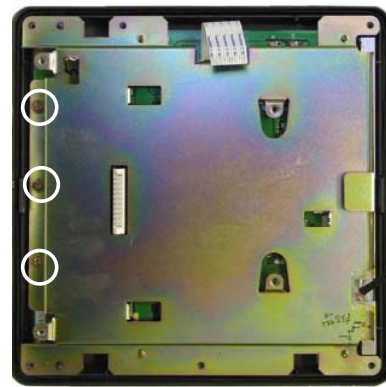

Fig.4-4

(3) PNL board

To remove LCD unit, loosen screws which secure the P.C. board to the panel.

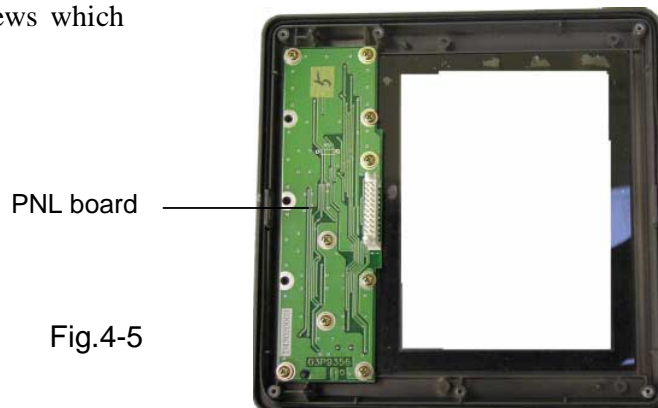

Fig.4-5

4.3 Replacement of Major Parts in Scanner unit

Fig.4-6 shows screws which fix boards to the chassis.

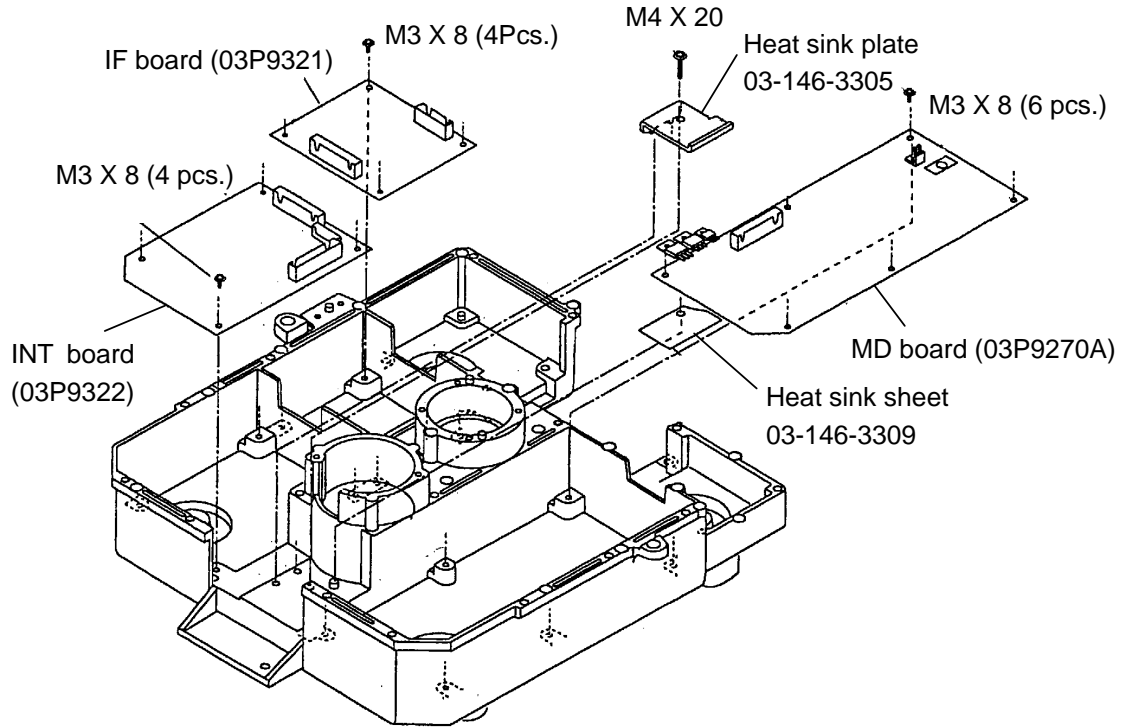

Fig.4-6 Boards in Scanner unit

4.4 Synchronous Belt and Motor

To remove the belt and motor:

1. Unscrew four M3x8 screws marked by *.
2. Remove the radiator assembly.
3. Replace the belt (or motor) with new one. No belt tension adjustment is necessary.
4. Reassemble the unit by reversing above steps.

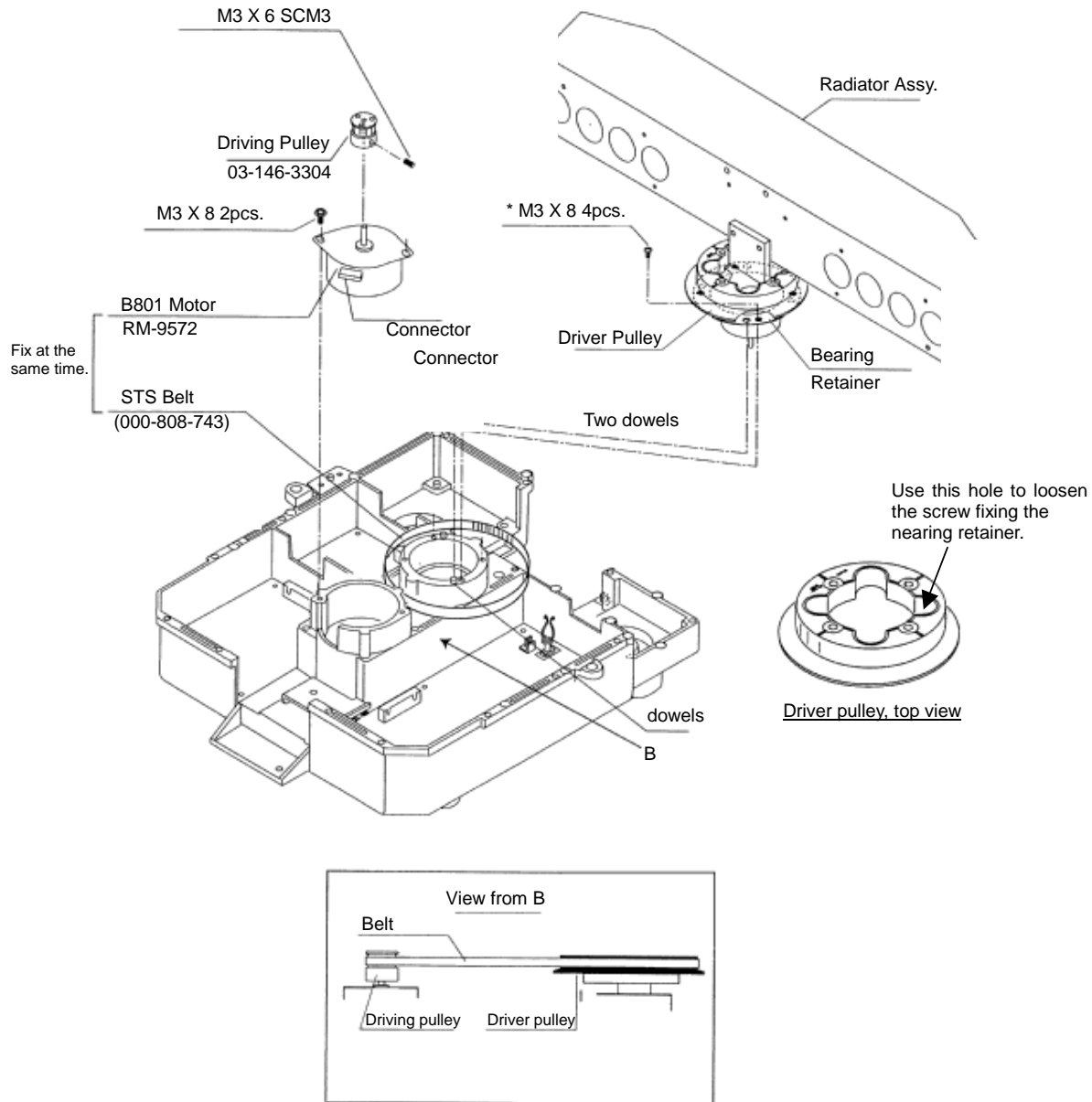

Fig.4-7

4.5 Magnetron

When handling the magnetron, taking the followings into account not to damage the magnetron physically and electrically.

- 1) Use a non-magnetic screw driver to dismount and mount the magnetron.
- 2) Keep the magnetron 25 mm away from the metals.
- 3) Never pull the magnetron lead wires.

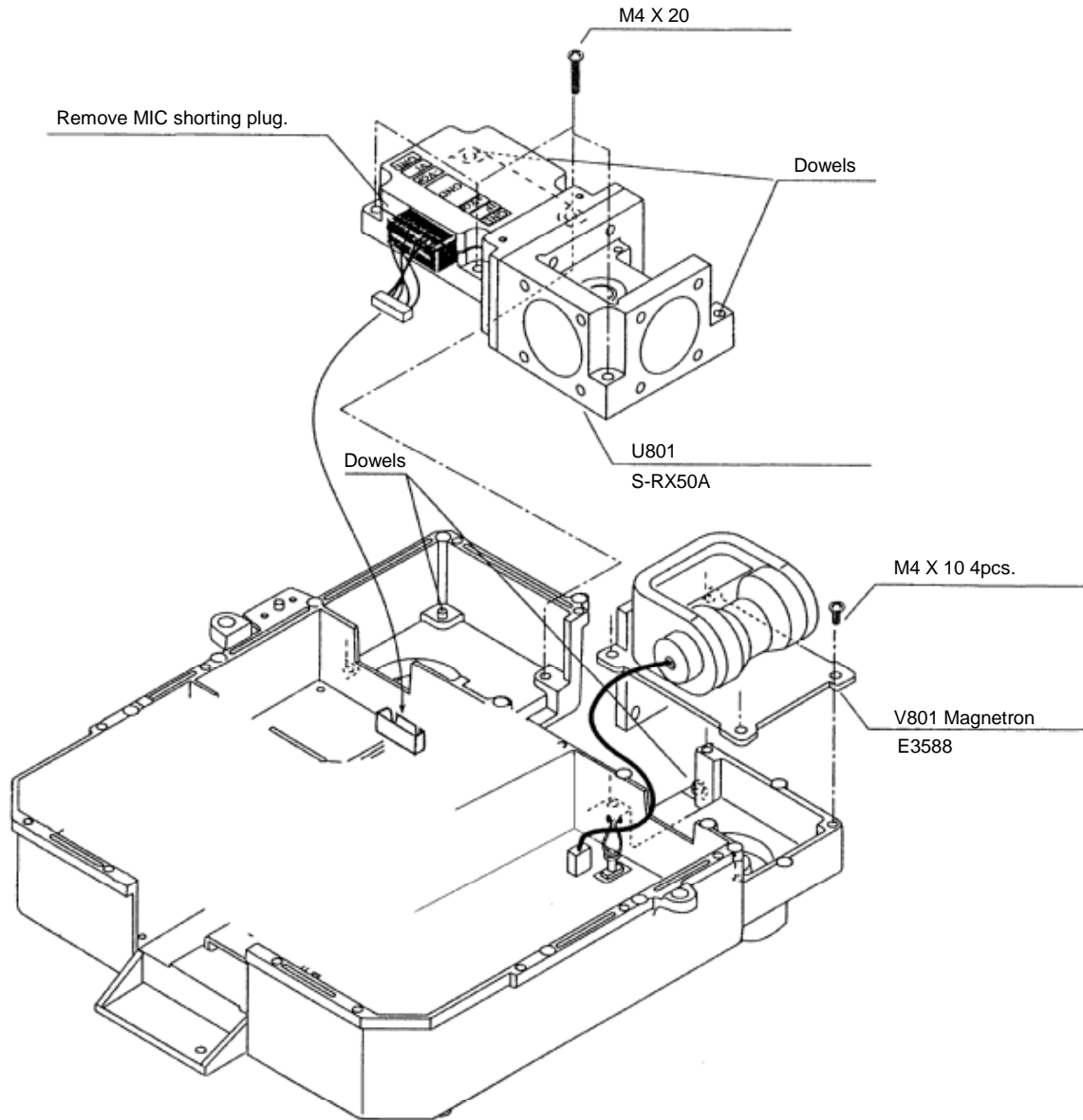

Fig.4-8

4.6 MIC

See Fig.4-8. Remove the MIC shorting plug before use.

4.7 Program updating

The program is upgraded by connecting a PC directly or through a RS232C-RS422 converter.

1. Direct connection of PC

1) Connection

The cover of the display unit is removed for the connection of the PC.

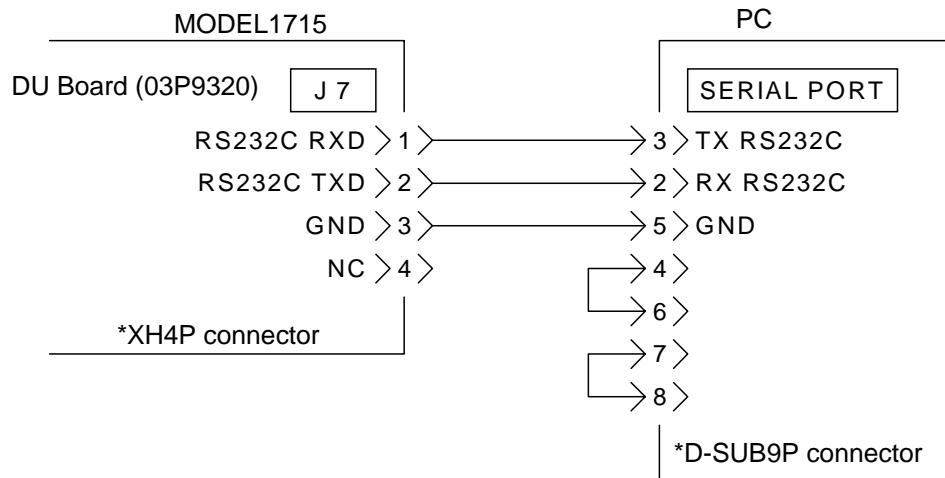

Fig.4-9

2) Procedure

1. Load the program file onto your PC.
2. Open the program file and then click the batch file, up1715.bat.
3. The message "TARGET POWER ON" appears.
4. Turn on the radar. The messages, "Now Erasing" and "000 percent completed" appear on the PC. When the message "Finish Version up" appears, the upgradation is completed. The system restarts automatically. Fig.4-10 shows the change of the display on the PC.
5. Disconnect the cable and close the cover of the display unit.

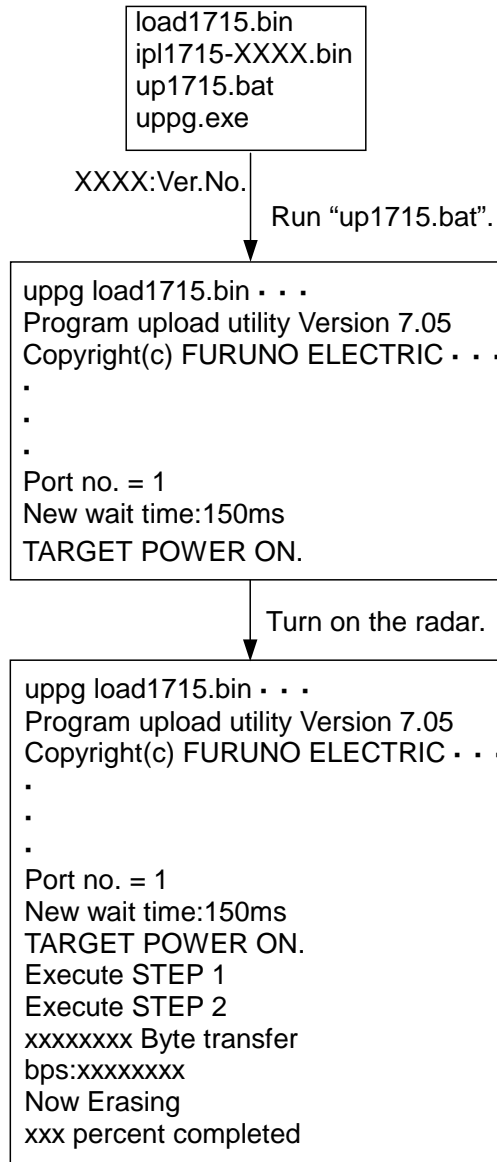

Fig.4-10

2. Using RS232C-RS422 converter

1) Connection

The PC is connected to the NMEA port on the rear panel of the display unit. See Fig.4-11.

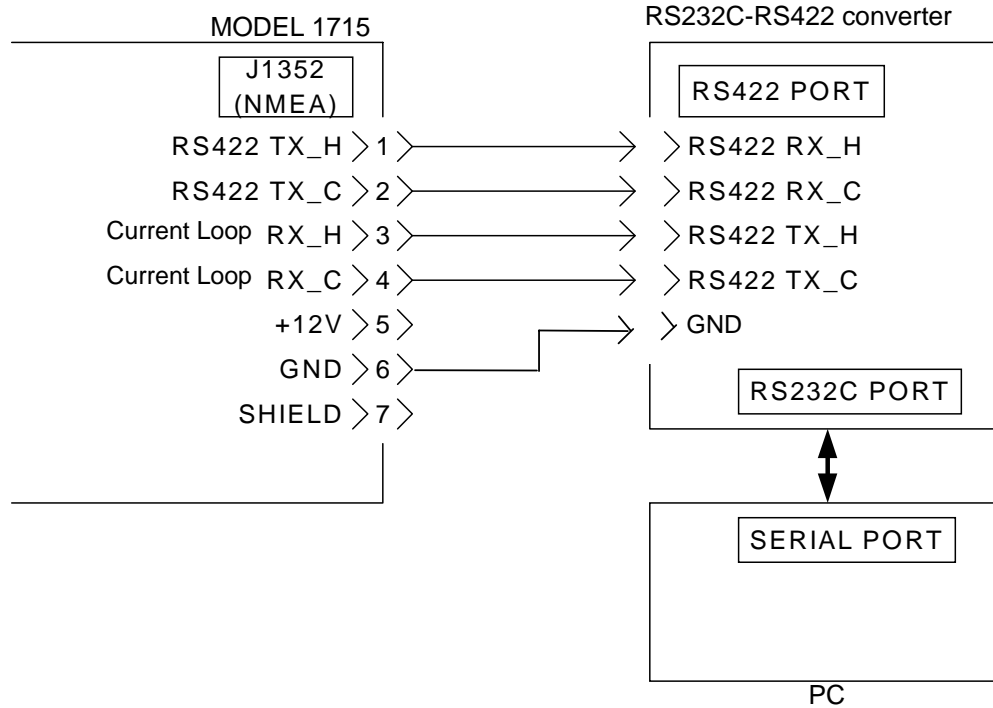

Fig.4-11

2) Procedure

See the procedure in the section “Direct connection of PC”.

To check program number:

1. Turn on the unit while pressing the MENU key.
2. The installation menu appears. Select “TEST” and press the right arrow key.
3. The program number is displayed in the test display. (0359216-0X.0X)
4. Turn off the unit.

Chapter 5 Troubleshooting

5.1 Error Messages

The following messages appear to call the operator's attention to missing heading or bearing pulses. Check the antenna cable for damage or discontinuity when these messages appear.

Table 5-1 Error Messages

Message	Meaning
NO HEADING PULSE	Heading pulse is not applied to the CPU on the DU board. The heading mark disappears.
NO BEARING PULSE	Bearing pulse is not applied to the CPU on the DU board. Radar automatically changes from TX to ST-BY mode.

5.2 Troubleshooting Matrix table

The troubleshooting matrix table on the next page helps the service technician to quickly identify defective pcb or block. To use the table, locate the symptom in one of the three columns of the table. Possibly defective circuits and their likelihood of defectiveness, identified by a circle, star or triangle, corresponding to 70 to 80 %, approximately 20 % and a few percent respectively, are listed in each column. Numeral inside circle shows degree of possibility; the smaller the number, the higher the possibility.

Note: Before consulting the table, check the ship's mains (input voltage at J1351#1(+) and #2(-) of the display unit: 10.8 to 31.2 VDC) and the power fuse.

Symptom	1) Power cannot be supplied. 2) Power is supplied but nothing appears on LCD. 3) Scanner does not rotate.			4) Marks and legends do not appear. 5) Marks and legends appear, but no noise nor echo. 6) Marks, legends, and noise appear but no echo.			7) Incorrect target bearing. 8) Poor sensitivity. 9) Keyboard is pressed but no response.		
	1	2	3	4	5	6	7	8	9
Check point									
DU board (03P9320)	②	①	②	①	☆	△	①	△	①
PNL board (03P9356)									☆
LCD display (EW50300FDWR)		△							
IF board (03P9321)					①			☆	
MD board (03P9270)						☆		△	
INT board (03P9322)			①						
Magnetron						①		①	
MIC					②			②	
Motor and belt			☆						
Fuse (5A)	①								

5.3 Self Test

The self test is performed by following steps below.

5.3.1 Display unit

To test the display unit:

1. Turn on the power while pressing and holding down the [MENU/ESC] key to show the Installation menu.

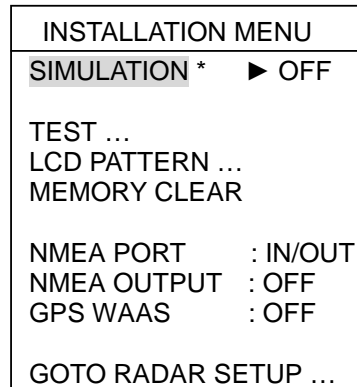

Fig.5-1 Installation menu

2. Press ▼ to choose test.
3. Press ► to start the test. In a few moments the results will appear. While the test result is shown, the brightness of the panel is changed to check the lighting circuit.

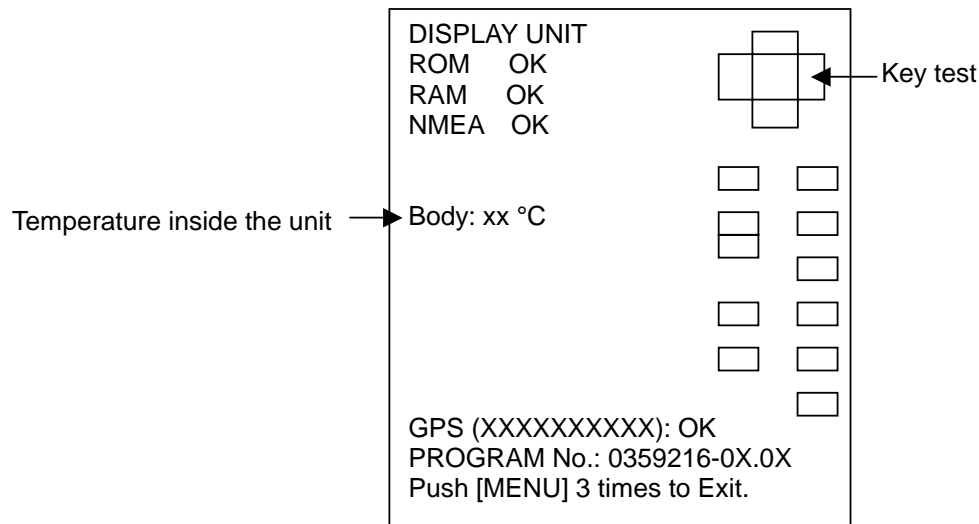

Fig.5-2 Test result

ROM: Sum check of the program ROM. The result is shown by “OK” or “NG”.

RAM: RD/WR check of DRAM

NMEA: Input and output check of NMEA port. NMEA port test is made by putting jumper wires between J1352#1 and #3, and #2 and #4.

NMEA Test result

OK: All input is good.

--: All input is no good.

01: NMEA1 (input from J1352#3 and #4) is no good or jumper wires are not connected.

02: NMEA2 (input from J1352#1 and #2) is no good.

03: The scanner communication with scanner unit is no good.

12: NMEA1 and NMEA 2 are no good.

13: NMEA1 and the communication with the scanner unit are no good.

23: NMEA2 and the communication with the scanner unit are no good.

Panel test: The pressed key is shown by black. To finish the test, press [MENU] three times.
The buzzer sounds at the end of the test.

GPS test: When the black box GPS (GP-310B etc.) is connected, the program number and the status of the GPS are shown. "OK" appears when the status is good and no indication when no good.

LCD test

1. Press ▼ to choose LCD PATTERN test.
2. Press ► to start the test. The entire screen is black.
3. Press [MENU/ESC] and the screen turns white.
4. Press [MENU/ESC] again and the screen shows a four-tone display.
5. To return to the installation menu. Press [MENU/ESC] again.

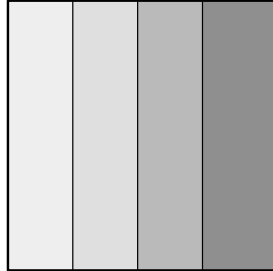

Fig.5-3

Clearing Back up memory

1. Select “Memory clear” in the Installation menu and press ►.
2. Select “Yes” to clear. The back up data is cleared when the system is turned on next time.

The following describes about other items in the installation menu.

- NMEA port setting: Sets NMEA port to “Input/Output” or “Input/Input”.
- NMEA output: Decides whether NMEA input is output from “output” port or not.
- GPS WAAS: Valid only when GP-320B is connected. Normally sets to “WAAS-02”.
- Go to radar setup: Entering into the scanner test menu.

5.3.2 Scanner unit

Follow the procedure below to test the scanner unit.

1. Press [MENU/ESC] to open the fourth page of the user menu.

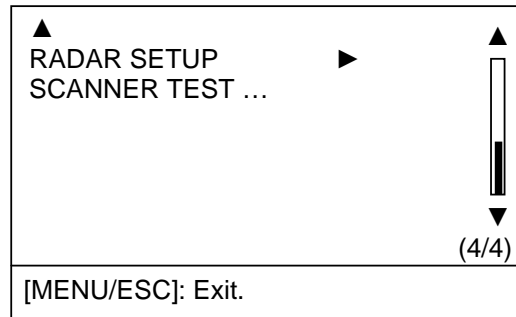

Fig.5-4 4/4 of user menu

2. Select “Scanner test” and press ►. The test starts and the result is displayed.

ANTENNA STATUS	: OK (xx)	Status code 8 bit data is displayed by hexadecimal number. When all tests are okay, 8bit data is 11110011 and the indication is (cf).				
HEADING	: OK					
BEARING	: OK (24.0 rpm)*	Bit 0: Power –on flag (LSB) 1: Tune voltage check 2: Gain voltage check 3: Heading signal 4: Not used (0) 5: Not used (0) 6: RAM check 7: Trigger signal (MSB) (0: Abnormal; 1: Normal)				
TUNE:						
TOTAL ON TIME	: 00000 h					
TOTAL TX TIME	: 00000h					
INPUT NMEA						
RMA	RMB	RMC	BWC	GLL	GGA	Sentences being received are in reversed video. →
MTW	VTG	VHW	XTE	VBW	DPT	
DBK	DBS	DBT	HDT	HDG	HDM	
BWR	GLC	GTD	MWV	ZDA		
[MENU/ESC]: Exit.						

* Long range = about 24.0 rpm
Medium range = about 31.0 rpm
Short range = about 41.0 rpm

Fig.5-5 Scanner test result

Note that ANTENNA STATUS is always NG (0) at the first test. Carry out scanner test again for correct reading.

ANTENNA STATUS is only the result of power-on flag test.

5.4 Test points on each board

1) DU board (03P9320)

Test point	Check Item	Ratings				Remarks
TP1 (TP4)	Q6-D	21.7 to 29.4 us				Switching Waveform
TP2 (TP4)	+5 V	4.8 to 5.2 Vdc				Adjuster: VR1
TP3 (TP4)	+9 V	8.7 to 9.9 Vdc				U9-#5
TP4	GND					
TP5	PC-					Reference Voltage (Primary)
TP6	VIDEO	Waveform 6				
TP7	VIDEO OUT	Waveform 6				
TP8	PW-S		SP	MP	LP	
TP9	PW-M	PW-S	0	1	1	
TP10	PW-L	PW-M	1	0	1	
		PA-L	1	1	0	
TP11	TRIG	36.85 to 40.85 kHz V=9.0 to 12.0 V, T=6.0 to 10.0 us				
TP12	BUSCLK	8.1725 to 10.7125 kHz				
TP13	BP	V=4.0 to 5.2 V, T=5.5 to 6.5 ms				
TP14	HD	V=4.0 to 5.2 V, T=2.5 to 2.9 S				
TP15	RST	0 V				4.8 V to 5.2 Vdc when turning on
TP16	PWR OFF	0 V				4.8 V to 5.2 Vdc when turning off
TP17	INV	V = 4.2 to 5.3 Vp-p T = 12.7 to 14.1 μS				Supply voltage for back light

2) MD board (03P9270)

Test point	Check Item	Ratings				Remarks
TP801/TP802	+9 V	8.7 to 9.9 Vdc				
TP803/TP802	VD1	34 to 46 kHz				Same wave as VD2
TP804-#1/ TP804-#4	-6 V	-6.2 to -5.8 Vdc				
TP804-#2/ TP804-#4	+5 V	4.75 to 5.25 Vdc				
TP804-#3/ TP804-#4	+12 V	11.9 to 12.1 Vdc				Adjuster: VR801
TP804-#5/ TP804-#4	Magnetron Current	3.05 to 3.15 V 3.35 to 3.45 V				TX long, Adjuster: VR851 TX short, Adjuster: VR852
TP804-#6/ TP804-#4	+8 V	7.8 to 8.2 Vdc				
TP804-#7/ TP804-#4	ST-BY/TX	8.5 to 9.35 Vdc (8.1 to 9.1 Vdc)				ST-BY (TX, 6 nm)
TP805/TP806	+12 V	11.9 to 12.1 Vdc				
TP807	GATE2	Waveform 2				Gate signal of switching FET
TP808	VD2	Waveform 3				
TP811	TRIG	Waveform 1				
TP812	GND					Not cold line of Ship's main
TP813	TX. PW.	Waveform 4				Pulse transformer drive signal
TP814	GATE1	Waveform 5				Gate signal of switching FET

3) INT board (03P9322)

Test point	Check Item	Ratings	Remarks
TP1	A/C RAIN	3.5 to 5.5 Vdc	
TP2	A/C SEA	0 to 4.5 Vdc	
TP3	CNTR 1		Not used
TP4	GAIN	5.3 to 8.5 Vdc	
TP5	GAIN CONT		Same wave as STC

4) STC waveform

Condition; TX, STC voltage (J809#9) adjusted to 3.5 ± 0.1 V manually.

Test point; Between R46 and R47.

Ratings; $V_1=3.5$ to 3.9 V, $V_2=1.5$ to 1.9 V, $V_3=0.5$ to 0.7 V, $T_1=50$ to 90 us

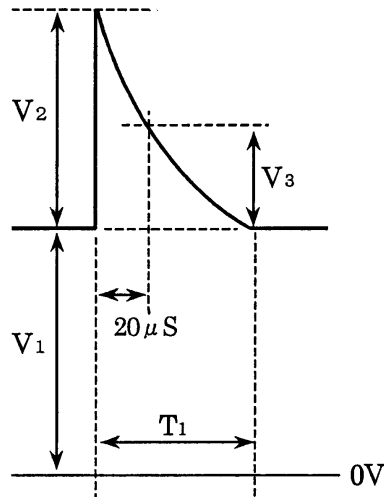
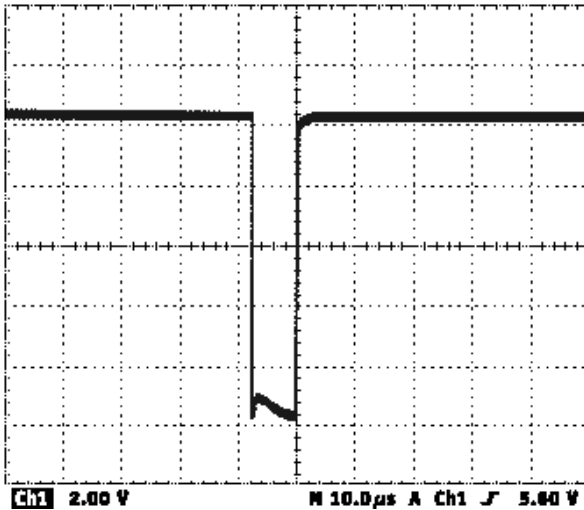

Fig.5-6 STC waveform



TP811 (TRIG.)

Vp-p=10 V

PW=8.0 μS

@TX-LONG

Setting on oscilloscope

2.00 V, 10.0 μs

Waveform 1

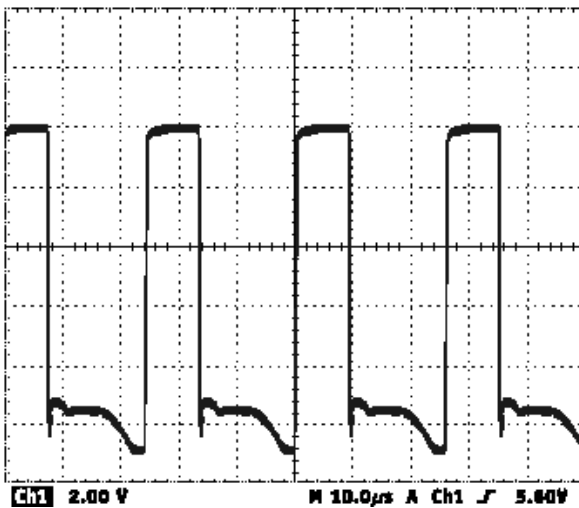

TP807 (GATE2)

Vp-p=10 V

f=38 kHz

@ power supply: 24 V

Setting on oscilloscope

2.00V, 10.0μs

Waveform 2

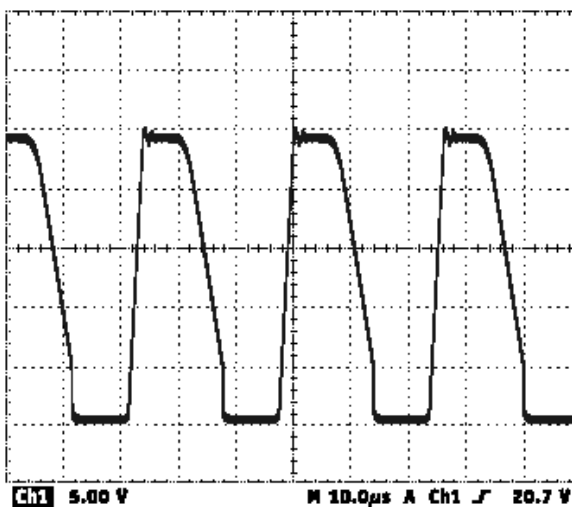

TP808 (VD2)

Vp-p=25 V

f=38 kHz

@ power supply: 24 V

Setting on oscilloscope

5.00 V, 10.0 μs

Waveform 3

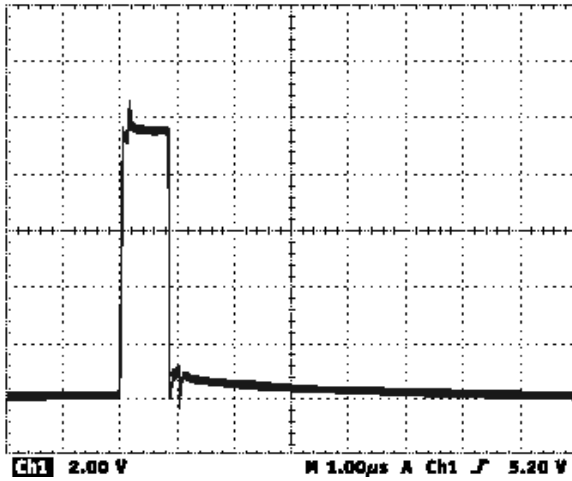

TP813 (TX.PW.)

Vp-p=10 V

PW=1.0 μs

@TX-LONG

Setting on oscilloscope

2.00 V, 1.00 μs

Waveform 4

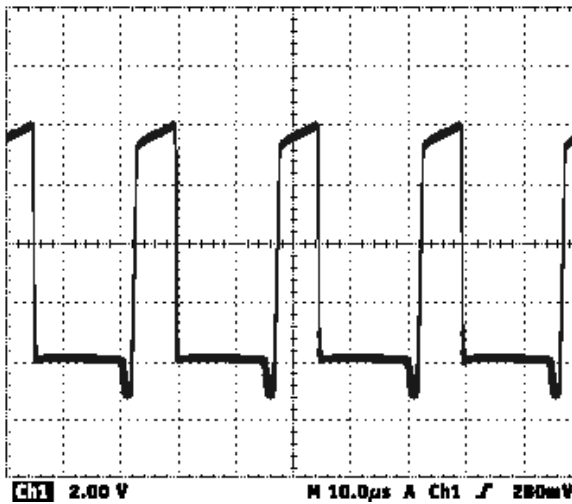

TP814 (GATE1)

Vp-p=8 V

f=40 kHz

@ power supply: 24 V

Setting on oscilloscope

2.00 V, 10.0 μs

Waveform 5

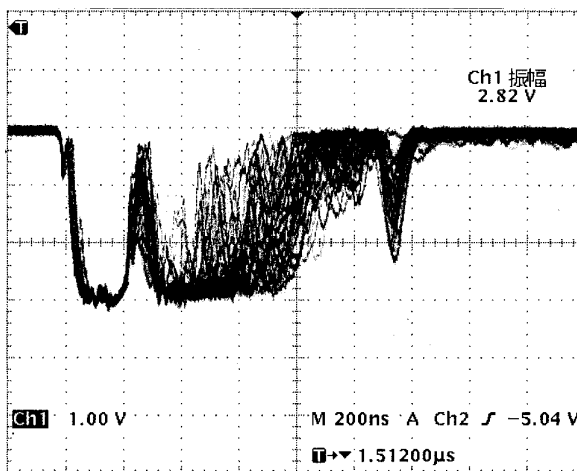

03P9269

TP602 (ECHO)

Echo appears after main bang
1 to 3 V

Setting on oscilloscope

1.00 V, 200 ns

Waveform 6

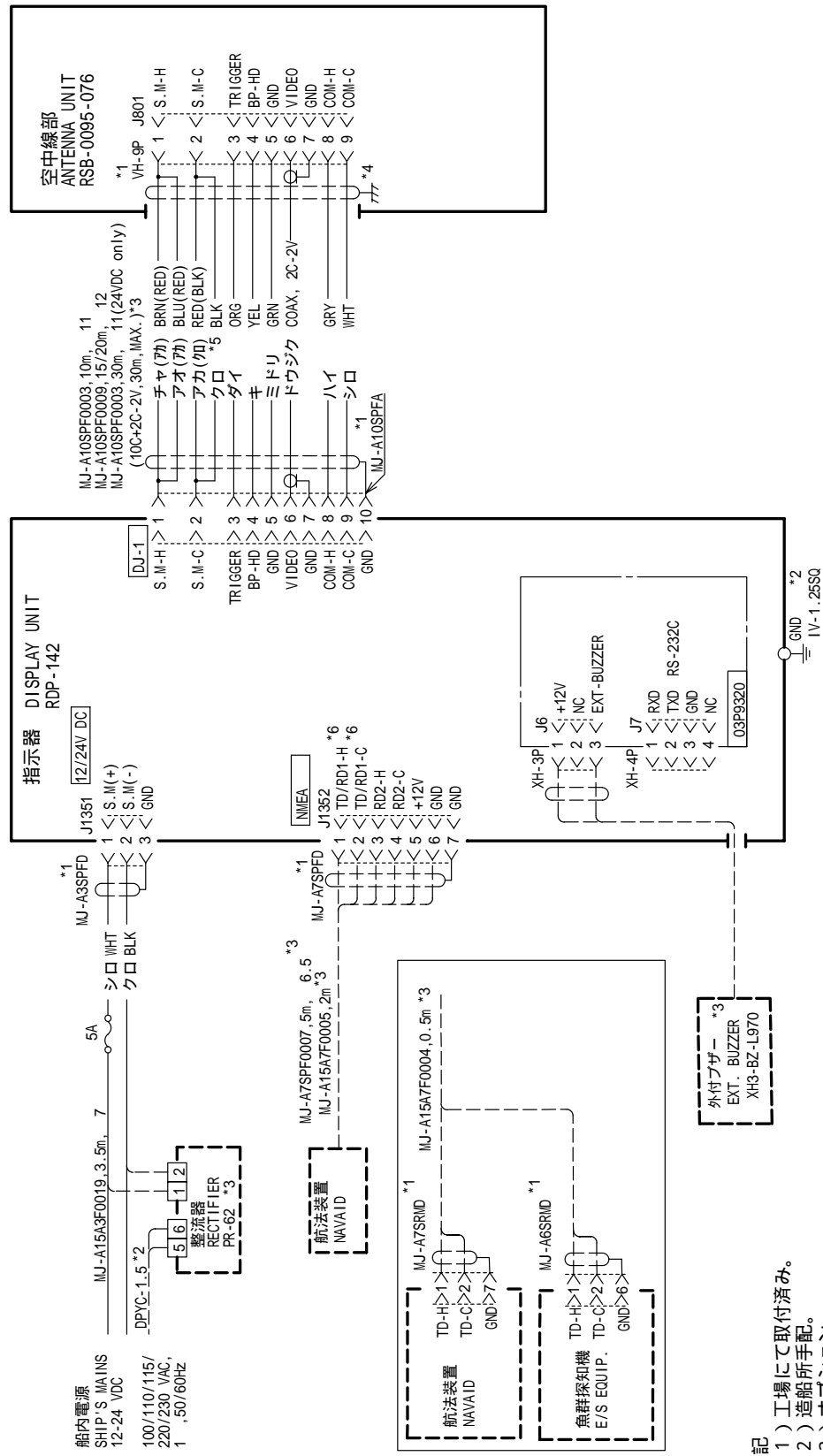

DRAWN	Jan. 31 '03	H. IMAKI	TITLE	MODEL 1715
CHECKED			名称	船舶用レーダー
APPROVED			相互結線図	
SCALE		MASS	NAME	MARINE RADAR
DWG. No.	C3514-C01 - A	kg		INTERCONNECTION DIAGRAM
				03-165-6001-0

注記

*1) 工場にて取付済み。
 *2) 造船所手配。
 *3) オプション。
 *4) 空中線部のシールドは完全にアースする。
 *5) () : MJ-A10SPF0009の芯線色を示す。
 *6) MJ-A15A7F0004使用時は、メニューでRDを選択。

NOTE

*1. FITTED AT FACTORY.
 *2. SHIPYARD SUPPLY.
 *3. OPTION.
 *4. GROUND EFFECTIVELY AT SCANNER UNIT.
 *5. () : WIRE COLOR OF MJ-A10SPF0009.
 *6. SELECT RD ON MENU WHEN MJ-A15A7F0004 CABLE IS USED.

A

B

C

D

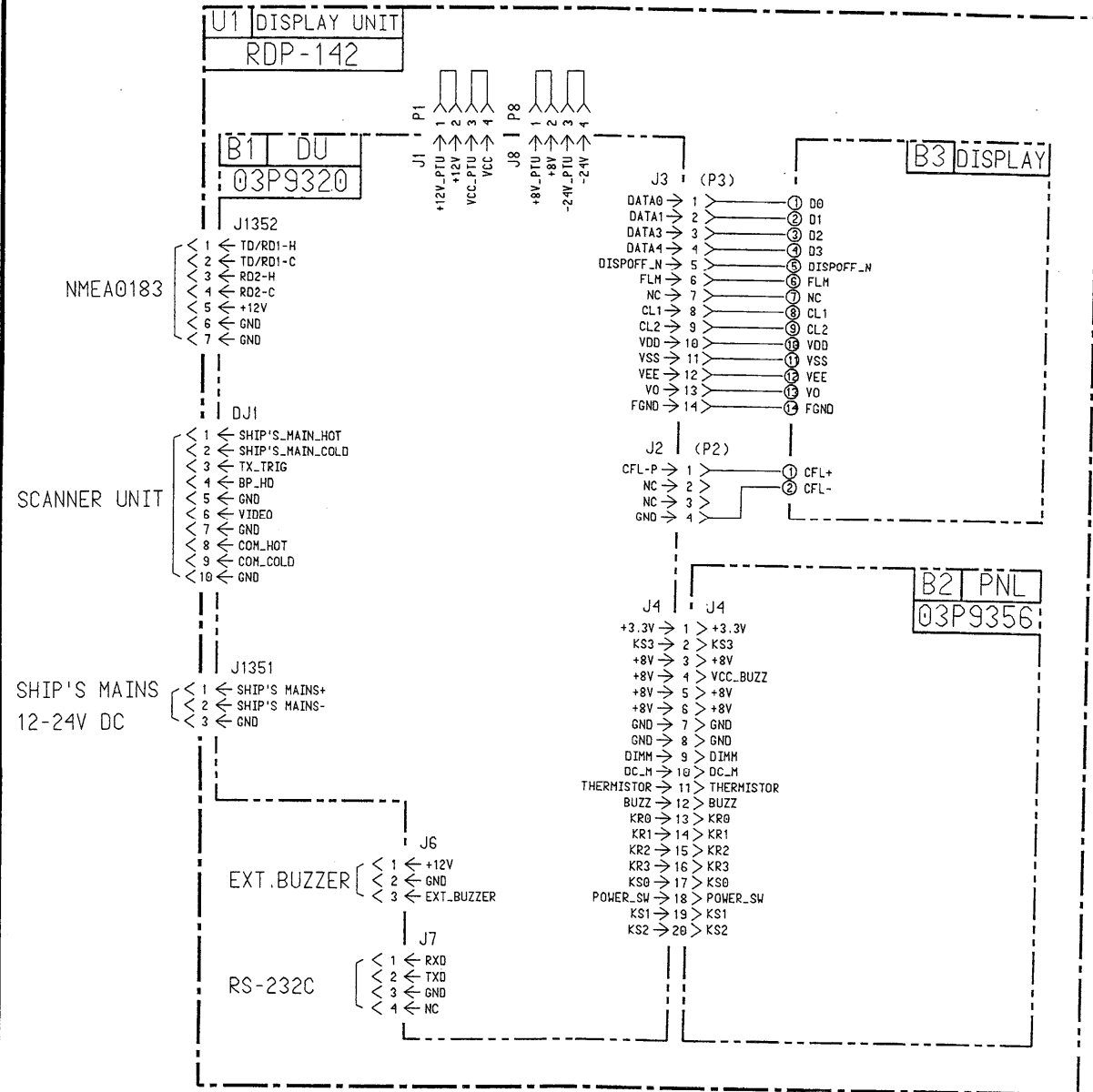

DRAWN 03/08/26 T. YAMASAKI		TYPE RDP-142	
CHECKED		名称 指示部	
APPROVED		回路図	
SCALE	MASS	MODEL 1715	NAME DISPLAY UNIT
Dwg No. C3514-K02- A		BLOCK No. 03-165-6002-0	SCHEMATIC DIAGRAM

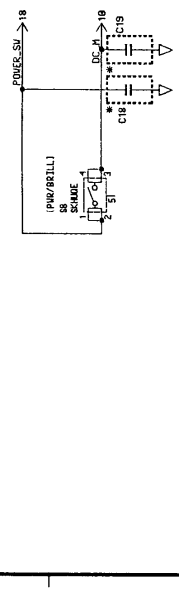
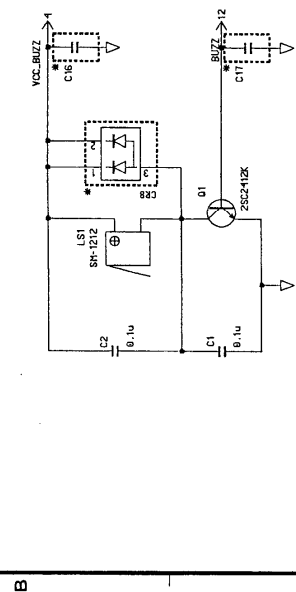
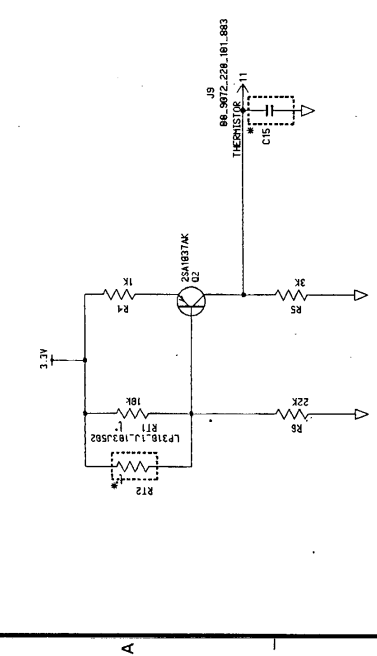
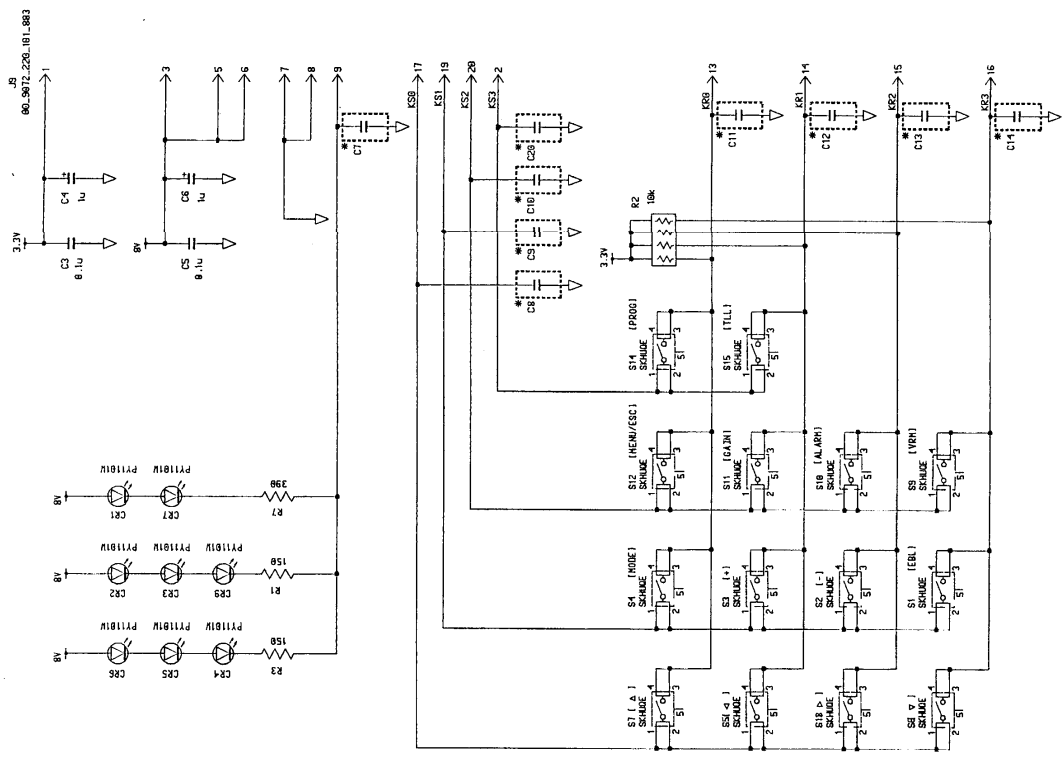

TYPE	C03P9356
名称	PNL基板
回路図	回路図
NAME	PNL PCB
SCHEMATIC DIAGRAM	SCHEMATIC DIAGRAM
DRAWN	03/08/26 T. YAMASAKI
CHECKED	23/08/26 T. Yamazaki
APPROVED	
SCALE	MASS
MODEL	ROP-142
BLOCK No.	
Dwg No.	C3514-K03-A
	C3-165-6004-0

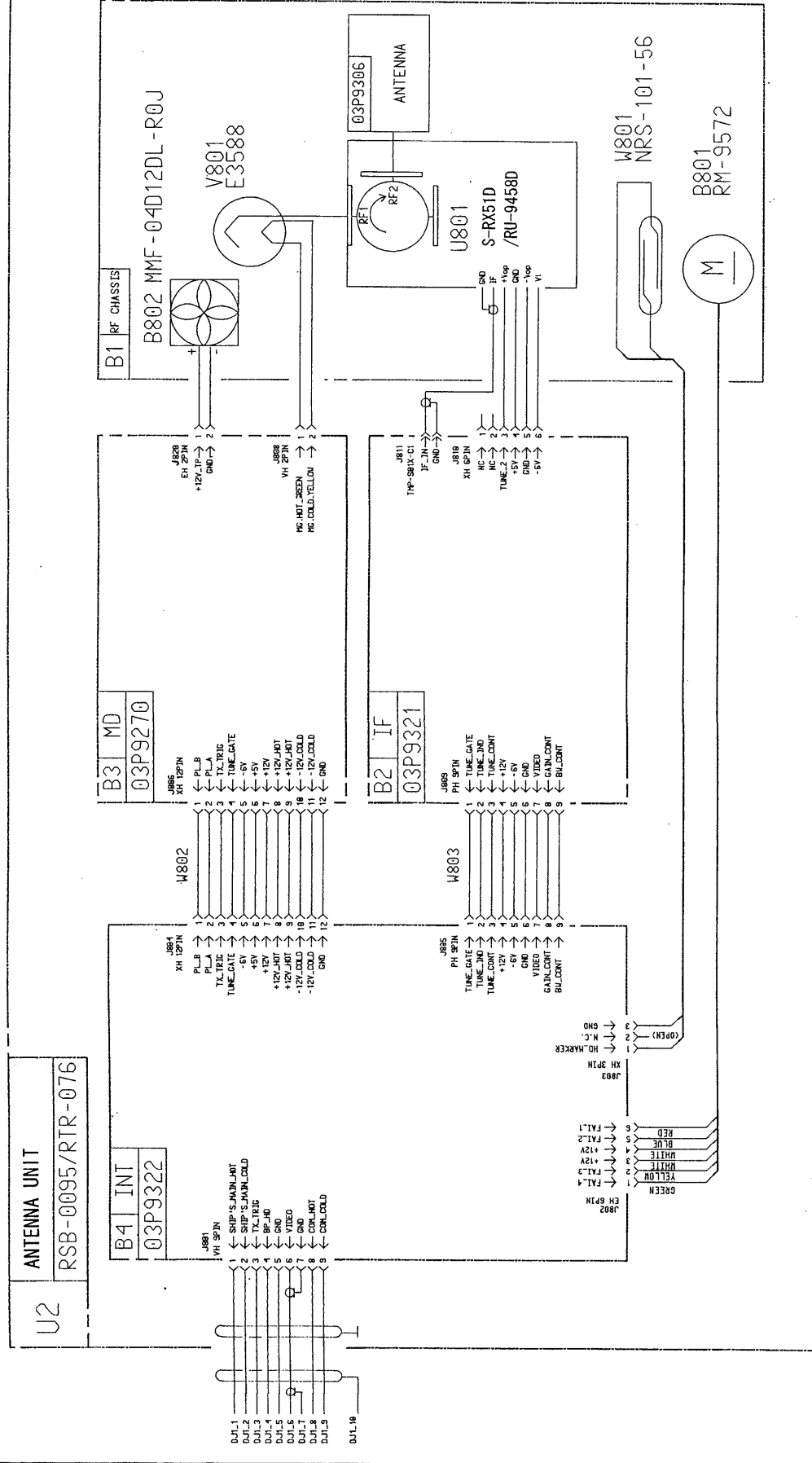

DRAWN	03/08/26	T. YAMASAKI	TYPE	RSB-0095/RTR-076
CHECKED			名称	空中線部
APPROVED			回路図	
SCALE	MASS	MODEL	MODEL No.	MODEL 1715
Dwg No.	C3514-K01-A		NAME	ANTENNA UNIT
				SCHEMATIC DIAGRAM
			BLOCK No.	03-165-6003-1

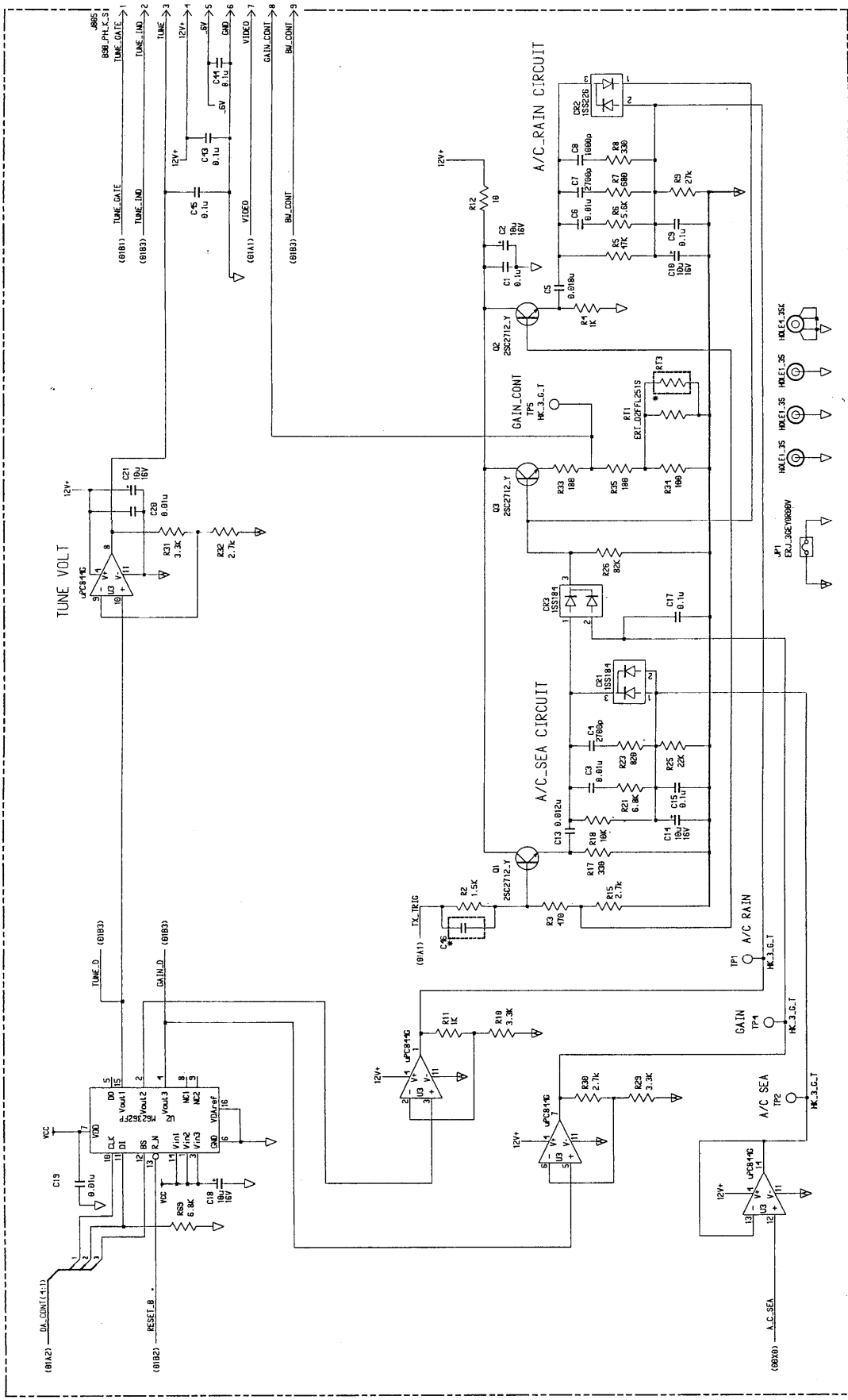

DRAWN	T. YAMASAKI	TYPE	03P9322 (2/2)
CHECKED	Y. F.	名称	INT 基板
APPROVED	Y. F.	回路図	回路図
SCALE	1:1	MODEL	INT PCB
Dwg No.	C3510-K06-A	BLOCK No.	03-160-6005-3
		SCHEMATIC DIAGRAM	

*: PATTERN ONLY.
 ** A/C SEA & RAIN Constants changed
 R19, R20, R21, R22, R23, R24, R25, R26, R27, R28, R29, R30, R31, R32, R33, R34, R35, R36, R37, R38, R39, R40, R41, R42, R43, R44, R45, R46, R47, R48, R49, R50, R51, R52, R53, R54, R55, R56, R57, R58, R59, R60, R61, R62, R63, R64, R65, R66, R67, R68, R69, R70, R71, R72, R73, R74, R75, R76, R77, R78, R79, R80, R81, R82, R83, R84, R85, R86, R87, R88, R89, R90, R91, R92, R93, R94, R95, R96, R97, R98, R99, R100.

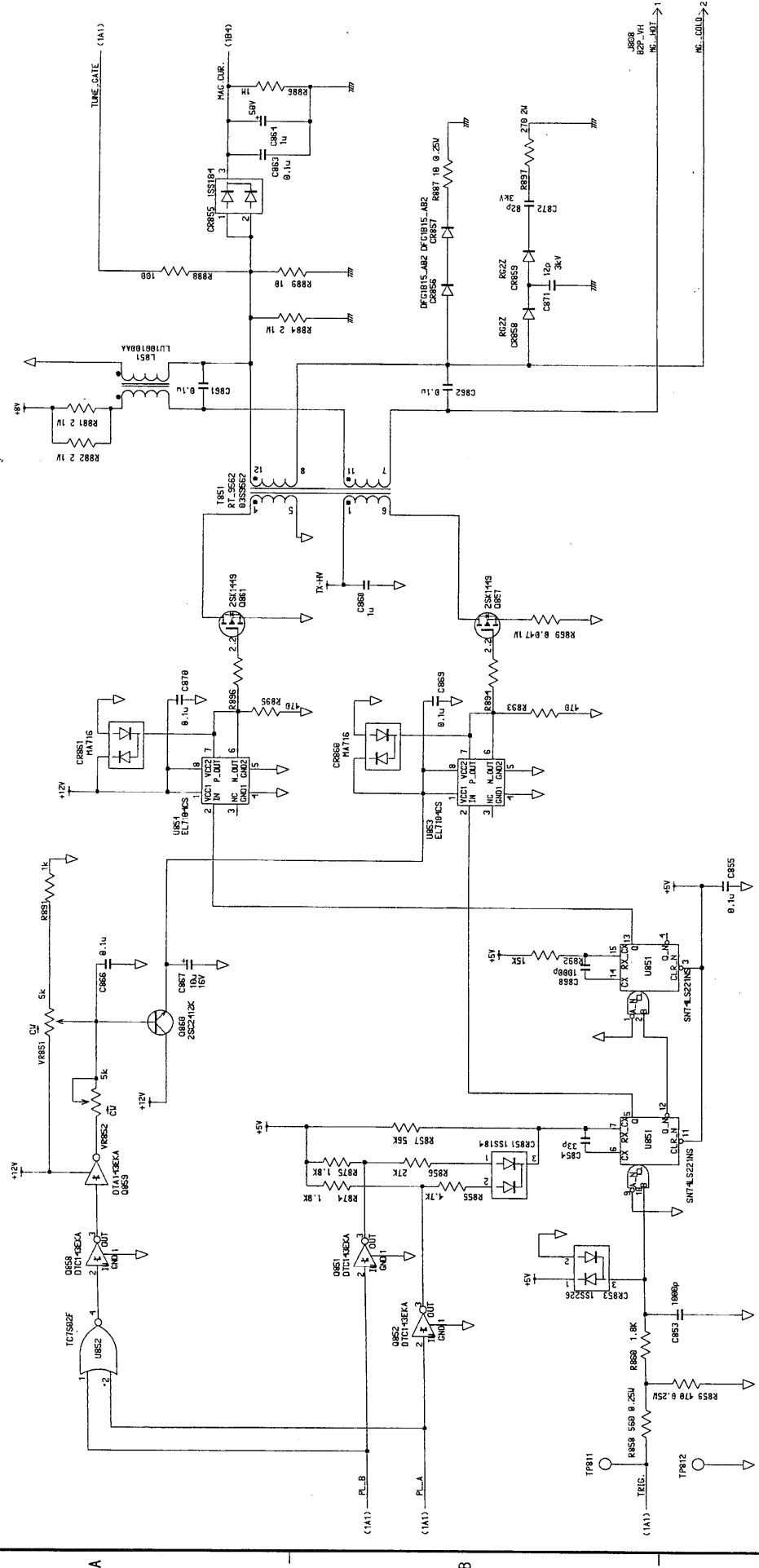

DRAWN	T. YAMASAKI	TYPE	03P9270 (2/2)
CHECKED	Y. K.	名称	MD基板
APPROVED	O. A. Y. K.	回路図	
SCALE	1/1	BLOCK No.	
	MODEL	NAME	MD PCB
Dwg No.	C3510-K08- A		03-146-6006-13
			SCHEMATIC DIAGRAM

NOTE
ALL RESISTANCE IN OHMS 1/10 W AND ALL CAPACITANCE IN FARADS, UNLESS OTHERWISE NOTED.

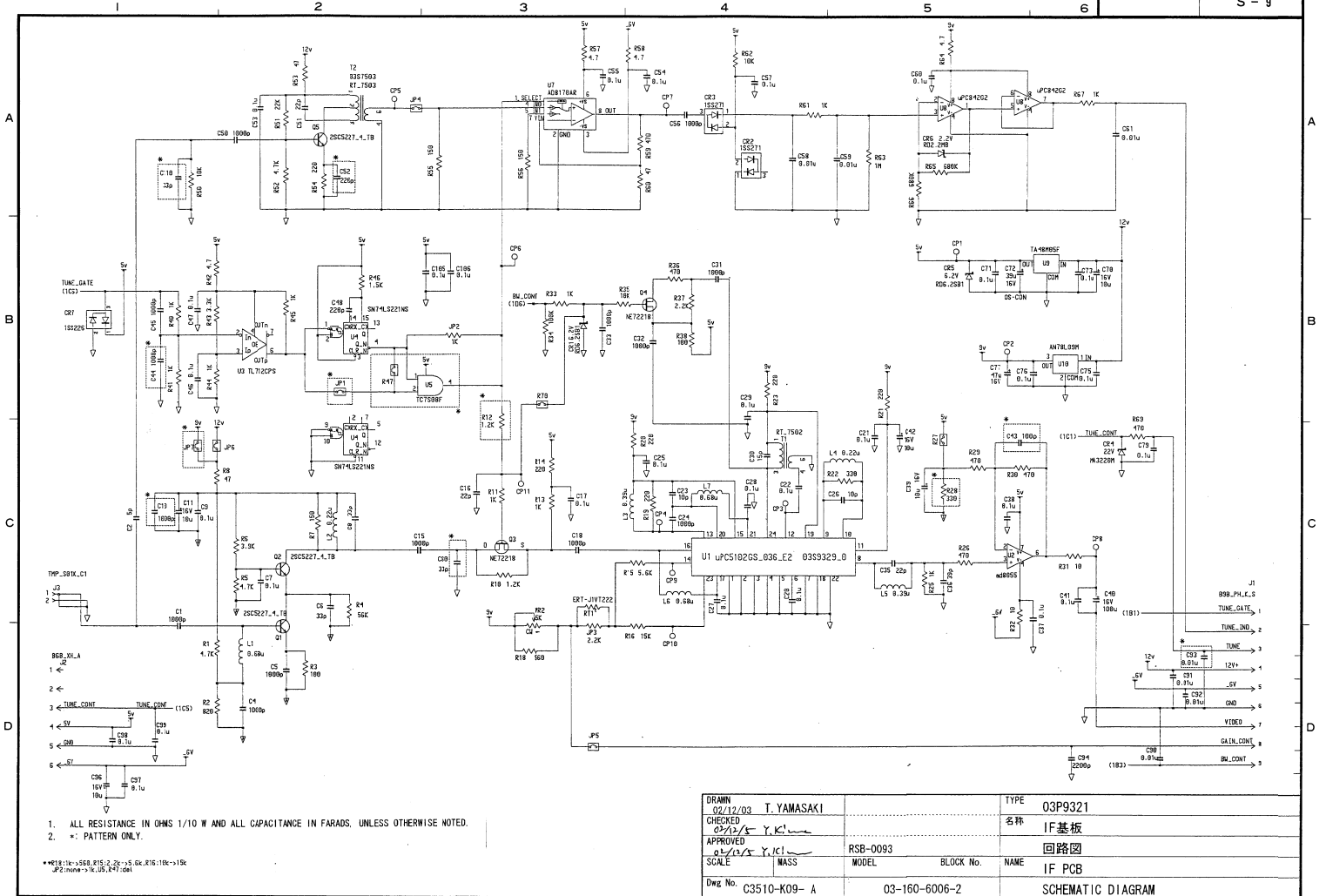

1. ALL RESISTANCE IN OHMS 1/10 W AND ALL CAPACITANCE IN FARADS, UNLESS OTHERWISE NOTED.
2. * : PATTERN ONLY.

*R18:11k→55k,R15:2.2k→5.6k,R16:10k→15k
 *P2:nom→1k,U5,R47 del

DRAWN	02/12/03 T. YAMASAKI	TYPE	03P9321
CHECKED	02/12/03 Y.K.	名称	IF基板
APPROVED	02/12/03 Y.K.	回路図	
SCALE	1/100	MODEL	RSB-0093
		BLOCK No.	
		NAME	IF PCB
Dwg No.	C3510-K09- A		
	03-160-6006-2		
			SCHEMATIC DIAGRAM

FURUNO ELECTRIC CO., LTD.

Other ManualsLib Projects



www.manualslib.com



www.manualslib.de



www.manualslib.es



www.manualslib.fr



www.manualslib.nl



www.manualslib.mx



www.manualslib.tech 30+ Languages