

# Development of a Radar Pulse Modulator

1973

Eckard Friedrich Natter  
*University of Central Florida*

Find similar works at: <http://stars.library.ucf.edu/rtd>

University of Central Florida Libraries <http://library.ucf.edu>

 Part of the [Engineering Commons](#)

## STARS Citation

Natter, Eckard Friedrich, "Development of a Radar Pulse Modulator" (1973). *Retrospective Theses and Dissertations*. 69.  
<http://stars.library.ucf.edu/rtd/69>

This Masters Thesis (Open Access) is brought to you for free and open access by STARS. It has been accepted for inclusion in Retrospective Theses and Dissertations by an authorized administrator of STARS. For more information, please contact [lee.dotson@ucf.edu](mailto:lee.dotson@ucf.edu).

DEVELOPMENT OF A RADAR PULSE MODULATOR

BY

ECKARD F. NATTER

RESEARCH REPORT

Submitted in partial fulfillment of the requirements  
for the degree of Master of Science in Engineering  
in the Graduate Studies Program of  
Florida Technological University, 1973.

Orlando, Florida

## ABSTRACT

This report summarizes the design of a 25kW peak power pulse modulator for an airborne medium-range weather radar.

It is the purpose of the modulator to collect and store energy over a certain time period and to form this energy into a short, high-power pulse.

The modulator is required to drive a coaxial magnetron with a pulse of 5kV at 5A. System considerations make a pulse width of 3.5us and a repetition rate of 99Hz necessary.

The pulse is generated in a line-type pulse circuit which utilizes an SCR as a switching device. It is shown that a solid-state modulator can use a commercial grade SCR for the pulse generation. Although currents of 100A are switched, the instantaneous power dissipation in the SCR is reduced significantly through the use of a saturable delay reactor.

A pulse transformer is used to achieve maximum power transfer from the modulator to the magnetron. The pulse transformer is insulated with a semi-rigid epoxy. Corona generation is avoided by limiting the voltage gradients in the insulation to 80V/mil.

## TABLE OF CONTENTS

ABSTRACT . . . . .	iii
LIST OF ILLUSTRATIONS . . . . .	v
1.1 PROBLEM PRESENTATION . . . . .	1
1.2 PREDESIGN CONSIDERATIONS . . . . .	2
1.3 INITIAL DESIGN . . . . .	4
2.1 EFFECTS OF PULSE TRANSFORMER PARAMETERS ON PULSE SHAPE . . . . .	10
2.2 PULSE TRANSFORMER . . . . .	16
2.3 THE PULSE-FORMING NETWORK . . . . .	21
2.4 SWITCHING CIRCUIT . . . . .	25
2.5 CHARGING CIRCUIT . . . . .	28
3.1 SUMMARY AND CONCLUSIONS . . . . .	31
APPENDIX . . . . .	32
BIBLIOGRAPHY . . . . .	34

## LIST OF ILLUSTRATIONS

Figure	Page
1. Block Diagram of Radar System . . . . .	1
2. Magnetron Characteristic . . . . .	3
3. Pulse Transformer and Magnetron . . . . .	5
4. Line-Type Pulse Generator . . . . .	6
5. Simplified Schematic and Voltage Waveforms of Modulator . .	9
6. Equivalent Circuit for Pulse Transformer . . . . .	10
7. Equivalent Circuit for Rise Time . . . . .	11
8. Voltage Rise of Pulse . . . . .	12
9. Equivalent Circuit for Top of Pulse . . . . .	13
10. Equivalent Circuit for Tail and Back Swing of Pulse . . . .	14
11. Winding Pattern . . . . .	17
12. Pulse Transformer (Actual Size) . . . . .	19
13. Corona Test Circuit . . . . .	20
14. T-Section of Delay Line . . . . .	21
15. Power Transfer Efficiency . . . . .	23
16. Capacitor Currents in Four-Section Pulse-Forming Network .	24
17. Power Dissipation in Main Switching SCR, No Delay Reactor .	26
18. Power Dissipation in Main SCR with Delay Reactor . . . . .	28
19. Resonant Charging Circuit . . . . .	29
A-1. Schematic of Modulator Printed Circuit Board . . . . .	32
A-2. Printed Circuit Board Layout . . . . .	33

## DEVELOPMENT OF A RADAR PULSE MODULATOR

### 1.1 PROBLEM PRESENTATION

The task is to develop a radar modulator for an airborne X-Band weather radar with a 200-mile range. This requires a nominal RF-output pulse of 10kW and  $3.5\mu\text{s}$  duration at a repetition rate of 99Hz. The block diagram of the radar is shown below.

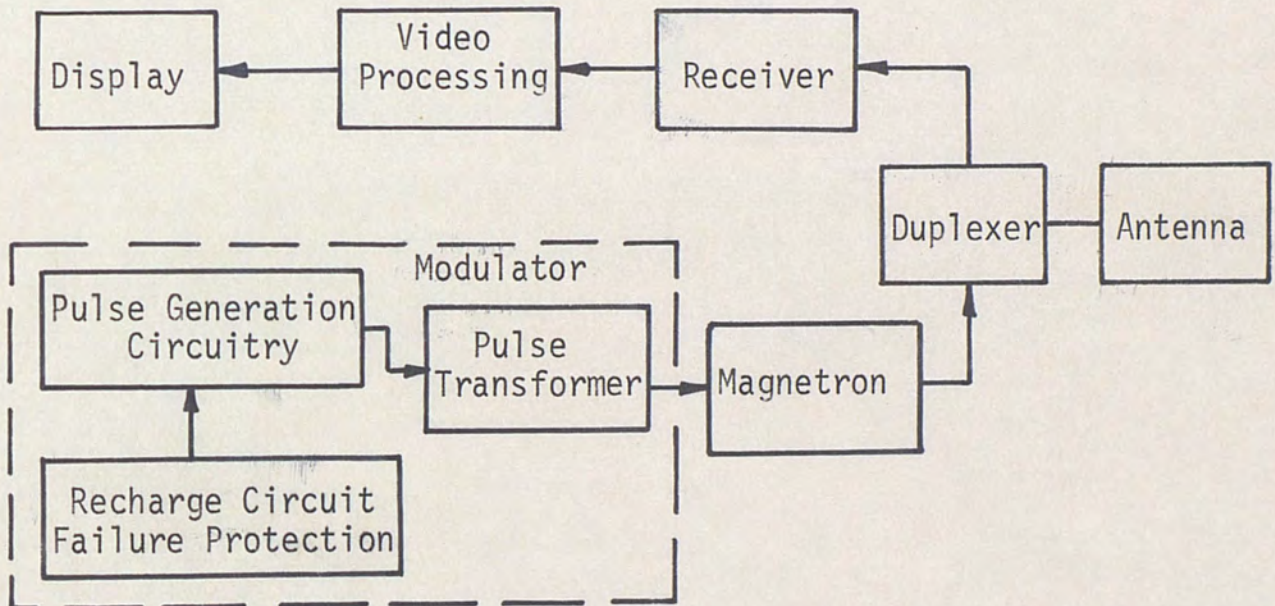

Figure 1. Block Diagram of Radar System

Reliability considerations make a coaxial magnetron necessary. The chosen magnetron (L5362)\* requires a drive of 5kV at 5A. The modulator under discussion consists of the following three areas:

- a) Impedance matching to magnetron by means of a pulse transformer.

\*Litton, Coaxial Magnetron L5362

- b) Pulse generation circuitry.
- c) Charging circuit and failure protection of modulator from arcing and misfire of magnetron.

## 1.2 PREDESIGN CONSIDERATIONS

The following guidelines are to be considered during the design phase of the modulator.

1. Solid-state design.
2. Low manufacturing costs and easy assembly through use of printed circuit board layout.
3. Light-weight construction.
4. Oil is not permitted as insulation material since possible leakage will reduce the reliability.
5. The temperature range of operation is from  $-55^{\circ}\text{C}$  to  $+100^{\circ}\text{C}$  with storage from  $-55^{\circ}\text{C}$  to  $+125^{\circ}\text{C}$ .  
Maximum operating altitude is 55,000 feet.

The modulator will drive a coaxial magnetron as shown in Figure 1. A magnetron is basically a magnetically biased vacuum diode that in its V-I characteristic is similar to a zener diode. The magnitude of the bias field influences the "knee voltage" of the magnetron, thus, changing the effective impedance. Figure 2 shows the V-I characteristic of the magnetron used.

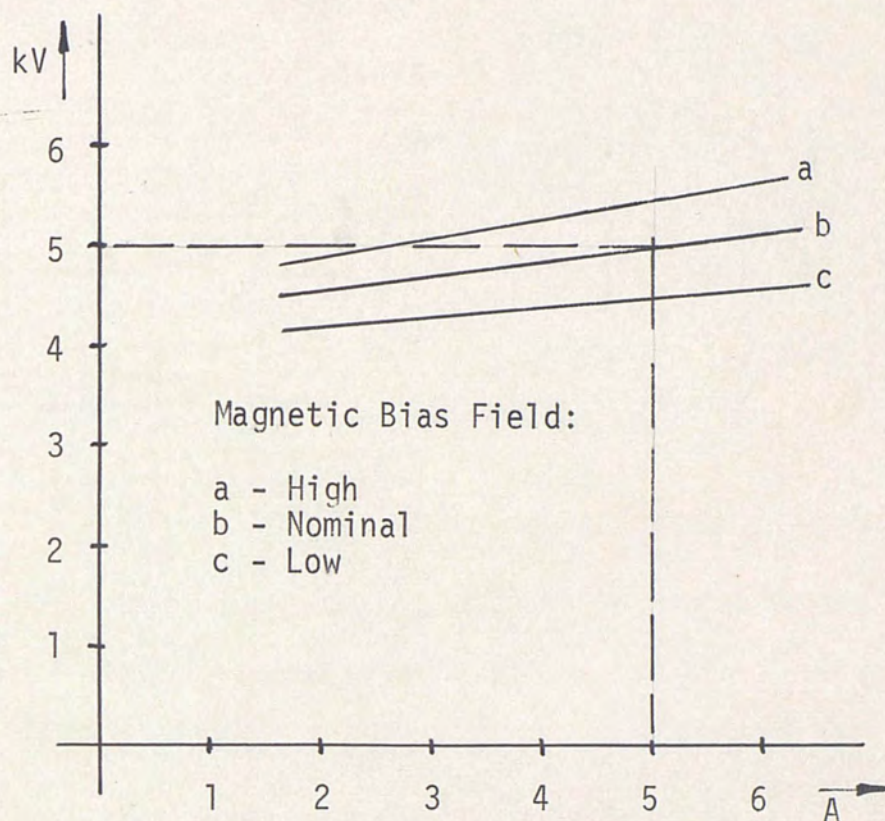

Figure 2. Magnetron Characteristic

The following problem areas are common under magnetrons and have to be considered to protect the modulator and assure reliable operation.

1. The cathode and filament are connected together, and since the anode of the magnetron is grounded, it has to be driven with a negative pulse at the cathode. Thus, the heater voltage "rides" on the pulse. Therefore, special attention must be given to the way the heater voltage is applied.
2. With increasing life, the tendency to misfire increases strongly. Misfire occurs when the pulse drive reaches its nominal value and the magnetron fails to conduct.



3. Arcing between anode and cathode can occur when the magnetron is misfiring or if the magnetron is subjected to a large mismatch in its microwave output.

### 1.3 INITIAL DESIGN

It is the purpose of the modulator to collect and store energy over a certain time period and to form this energy into a short and high-powered periodic pulse.

The three sections of the modulator are:

- a) The pulse transformer for impedance matching.
- b) The pulse generation circuitry also called pulse-forming network.
- c) The charging circuit that charges the pulse-forming network and provides failure protection.

The input impedance of the magnetron has to be matched to a suitable modulator output impedance to assure maximum power transfer. A pulse transformer is a solution for this problem. A dual secondary winding, if connected as in Figure 3, can be used to apply the heater voltage and as a series resistor for the heater of the magnetron to limit a high switch-on current. This switch-on current is large since the cold filament of the heater has only approximately 1/8 of the resistance it has in operating condition.

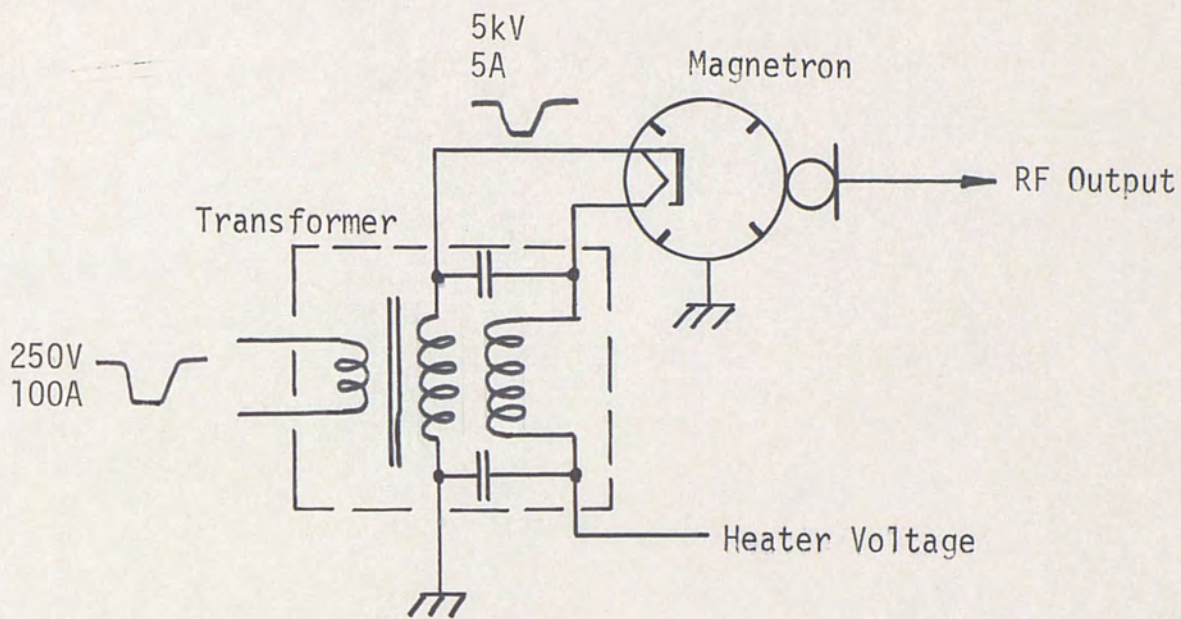

Figure 3. Pulse Transformer and Magnetron

Since there are no solid-state devices available that can switch 5kV, the pulse transformer is also used as a voltage transformer to reduce the pulse voltage. A 20 to 1 step-up ratio is an optimum. This ratio will bring the primary pulse down to 250V and 100A. Neglecting losses, the primary pulse requirements of the transformer are then 250V and 100A. This is a primary impedance of

$$\frac{250V}{100A} = 2.5 \Omega$$

For the pulse-forming circuitry, two different concepts are considered--a magnetic pulse-shaping circuit versus a line-type pulse generator. The two circuits differ in the way the pulse energy is stored. The magnetic modulator stores the energy in the magnetic field of an inductor. The line-type modulator stores

the energy in the electric field of a capacitor. Weight and volume considerations eliminated the magnetic modulator.

A line-type pulse generator is shown in Figure 4.

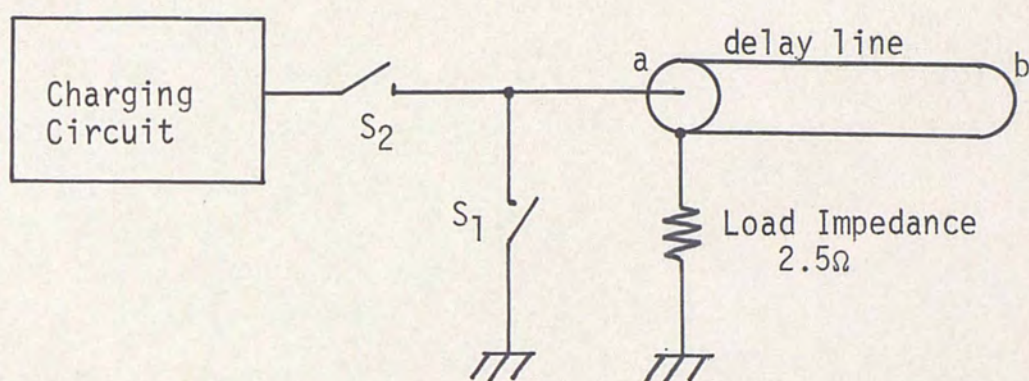

Figure 4. Line-type Pulse Generator

When the switch  $S_1$  closes, the voltage in the charged delay line will divide between the load resistor and the characteristic impedance of the line. If the load impedance equals the characteristic impedance of the delay line, the voltage will divide equally. The pulse width is equal to twice the delay time of the line. This can be understood by imagining that when the switch  $S_1$  closes, a step function is introduced at the input of the line (point a). This step function travels down the line, is reflected at the open end (point b), and travels back to the input (point a) where no reflection occurs. Thus, the step-function needs twice the delay time to deplete the line of its charge.

Distributed delay lines can only be used for relative short pulses because of their large volume per unit delay. A lumped

element delay line has a much lower volume per unit delay, however, the number of sections used is critical to rise and fall time of the pulse. The more sections used, the steeper the rise and fall times, and the lower is the ripple on the pulse; thus, volume, weight, and cost are increased.

The charging voltage of the line is estimated (not considering losses) to be

$$2 \times 250V = 500V$$

which is easily switched by an SCR. The SCR used is a 2N4444 with a 600V forward breakdown rating.

Failure considerations cover three different phenomena: latch-up of switching SCR, misfire, and arcing of magnetron.

Latch-up of the modulator occurs when the main switching SCR fails to turn off after the pulse-forming network is discharged. This problem is avoided if the recharge of the delay line occurs after the pulse loop has settled and the main switching SCR has turned off. The recharge is delayed through switch  $S_2$  in Figure 4. To prevent a latch-up,  $S_1$  and  $S_2$  are not closed simultaneously. Switch  $S_2$  is the recharge delay.

Misfire of the magnetron (failure to conduct) results in at least twice the voltage being generated by the pulse-forming network. This problem is commonly avoided by placing a gas filled spark gap across the magnetron. The firing voltage of the spark gap has to be considerably larger than the nominal "knee voltage" of the magnetron. Rather than using a spark gap, the pulse transformer was designed to withstand 2.5 times the nominal voltage, 13kV.

In case the magnetron misfires, the pulse transformer should saturate as quickly as possible but without affecting the pulse shape. The saturated transformer, being nearly a short, will then reverse charge the pulse-forming network. At this point, a reverse voltage limiter will absorb the charge before the pulse-forming network is recharged. This is, of course, only possible with the above described recharge delay.

Arcing inside the magnetron is, for the modulator, the same as a short and covered by the above circuitry.

Switch  $S_2$  is realized with another SCR; however, since  $S_2$  is riding on the supply voltage, the SCR is turned on through a trigger transformer.

The delay between "firing" the main SCR ( $S_1$ ) and the control SCR ( $S_2$ ) is realized through an R-C network which differentiates the trigger pulse to the modulator. The leading edge of the trigger pulse turns the main SCR on and the trailing edge turns the control SCR on.

The applied trigger pulse is  $250\mu\text{s}$  long. This determines the delay between the conduction of both SCR's.

There still exists the possibility that  $S_1$  will conduct if a transient voltage is induced on the trigger input when the current through  $S_2$  is above the holding current of SCR- $S_1$ . This is a latch-up condition. Both SCR's are conducting and can only be turned off if the current path is interrupted. A relay serves this purpose. The relay coil serves as a current sensor and opens the contacts  $S_3$  of Figure 5 if the current drawn from the power supply exceeds .15A.

Figure 5 shows a simplified schematic with the appropriate voltage wave forms.

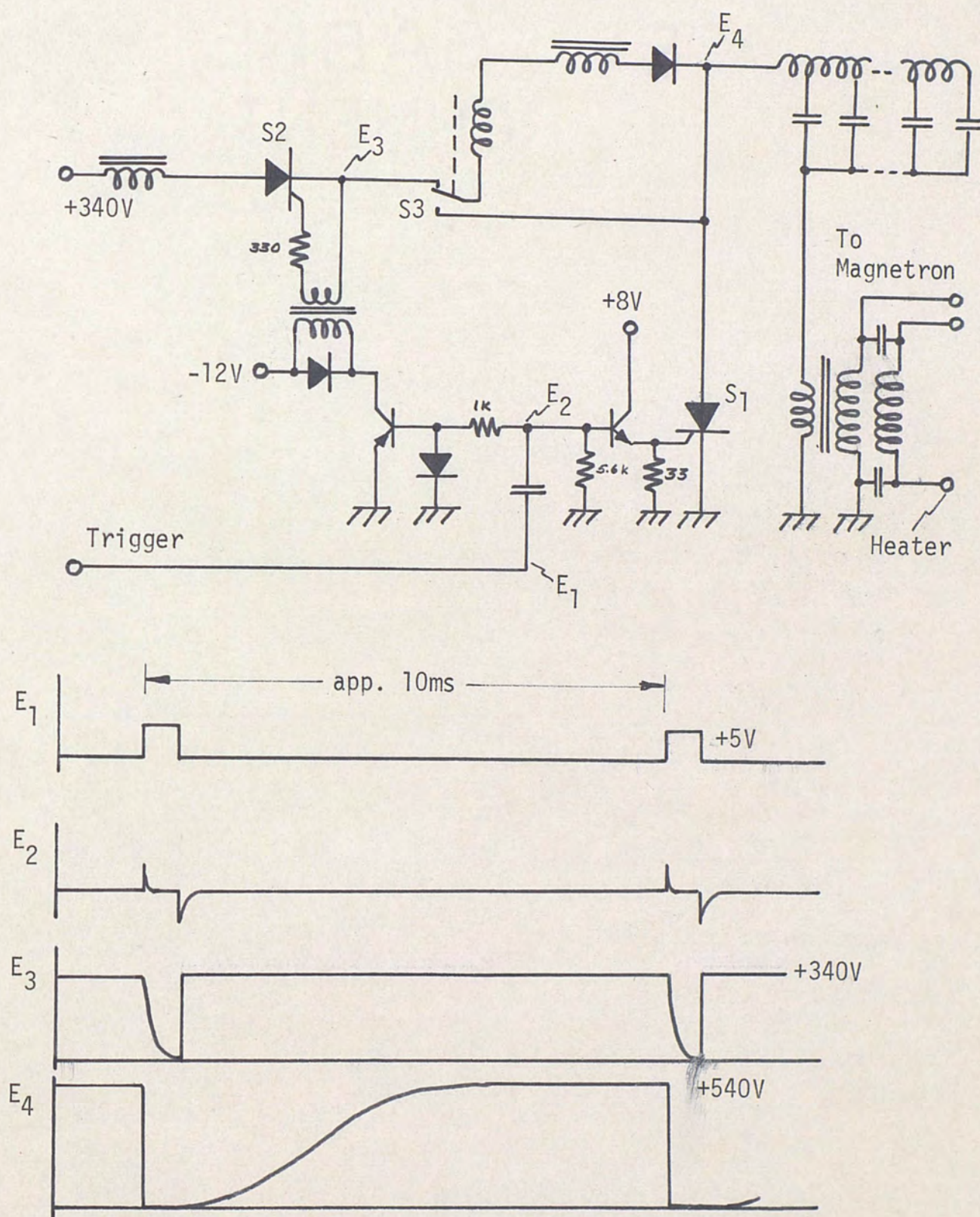

Figure 5. Simplified Schematic and Voltage Waveforms of Modulator

## 2.1 EFFECTS OF PULSE TRANSFORMER PARAMETERS ON PULSE SHAPE

The effect of the pulse transformer (with a biased diode or magnetron as load) on pulse shape has to be viewed in three different time segments. This is necessary since the load is nonlinear. The three time intervals are as follows:

- a) Rise time of pulse until load conducts.
- b) Top of pulse with low dynamic load impedance.
- c) Tail and backswing of pulse due to the energy stored in the magnetic field of the core,  $L_e$ .

An electromagnetic transformer is reasonably well approximated in the equivalent circuit of Figure 6. Losses of primary and secondary windings (copper losses) are neglected.

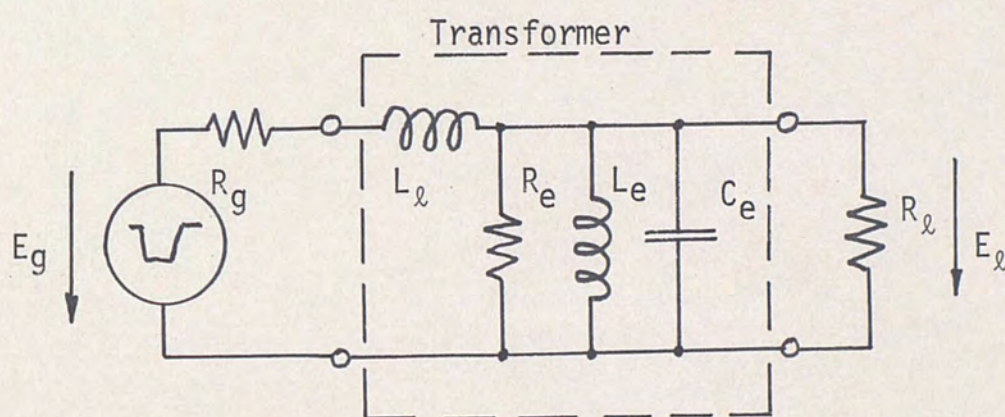

Figure 6. Equivalent Circuit for Pulse Transformer

- $E_g$  -- Ideal Negative Pulse Source
- $R_g$  -- Internal Impedance of Source
- $L_l$  -- Lumped Leakage Inductance

- $R_e$  -- Equivalent Resistor Representing  
 Losses in Primary and Secondary  
 Winding and Core  
 $L_e$  -- Primary Inductance  
 $C_e$  -- Lumped Equivalent of Distributed  
 Capacitance Between Windings.  
 $R_l$  -- Load Impedance  
 $E_e$  -- Output Voltage

The rise time of the pulse on a magnetron or biased diode load is considered for a transformer in which the effect of  $R_e$  is negligible compared with  $R_g$  and where the rise time is so short compared with the pulse length that  $L_e$  is also negligible. This leaves the equivalent circuit of Figure 7.

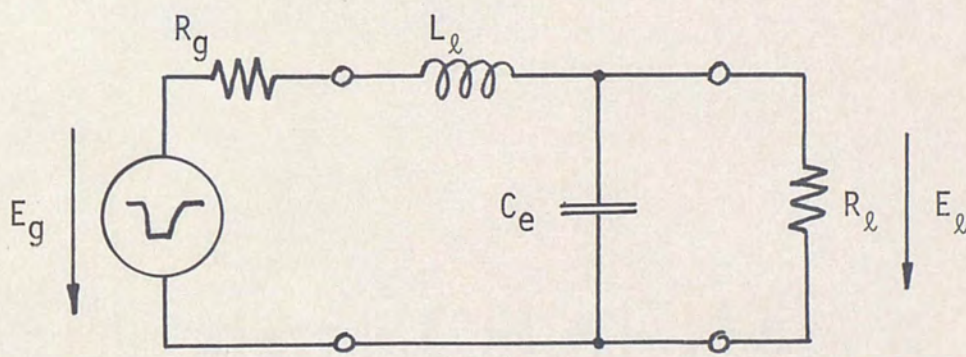

Figure 7. Equivalent Circuit For Rise Time

Since  $R_l$  is usually much larger than  $R_g$ , the output voltage will rise quickly until

$$\frac{E_l}{E_g} = 1$$



Up to that point, only  $R_g$ ,  $L_\ell$ , and  $C_e$  determine the transfer function because of the non-conducting magnetron with its high dynamic impedance. Figure 8 shows the transfer function.

$$\frac{E_\ell}{E_g} = \frac{R_\ell}{R_g + R_\ell} \left[ 1 - e^{-\frac{t}{\tau}} \cos \left( \frac{t}{\sqrt{L_\ell C_e}} \right) \right]$$

$$\frac{1}{\tau} = \frac{R_g}{2L_\ell} + \frac{1}{2C_e R_\ell} \quad \left| \quad 0 < \frac{E_\ell}{E_g} < 1 \right.$$

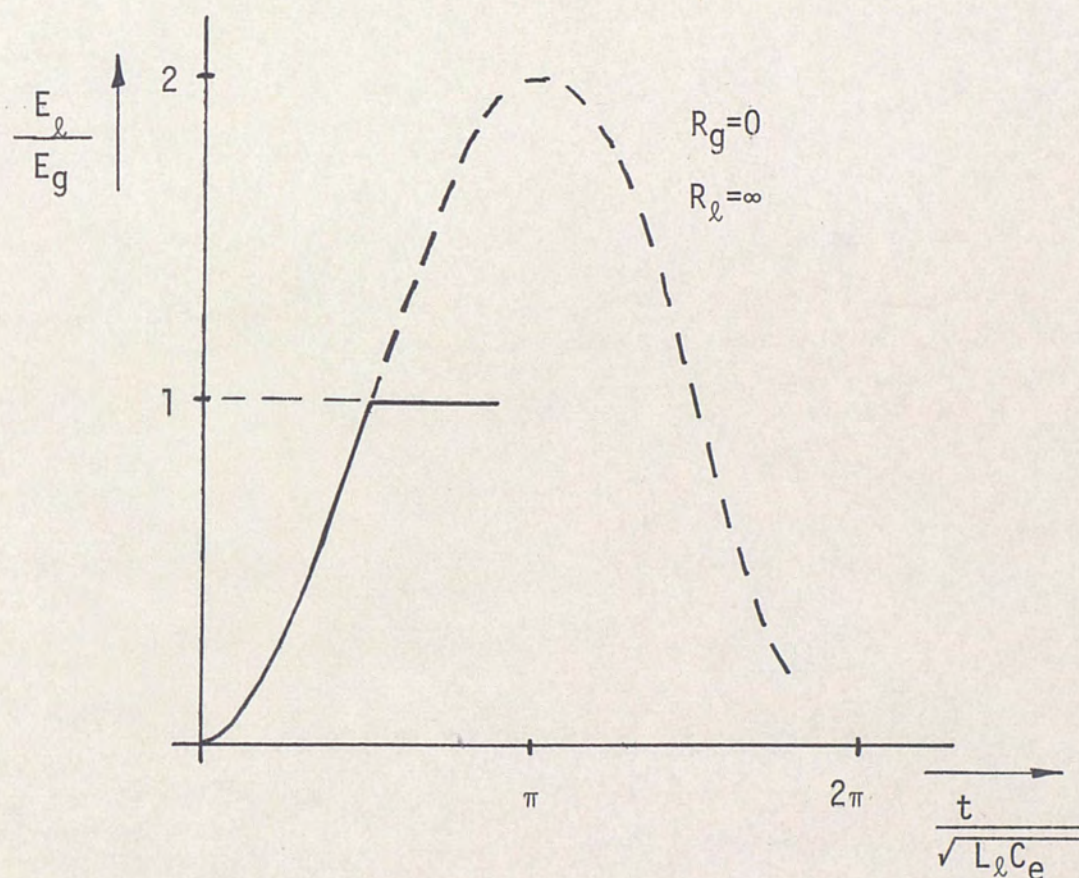

Figure 8. Voltage Rise of Pulse

The top of the pulse starts when the transfer function becomes unity. At that point, the biased diode or magnetron conducts and  $R_e$  becomes less than  $R_g$ . Now a new equivalent diagram is valid, Figure 9.

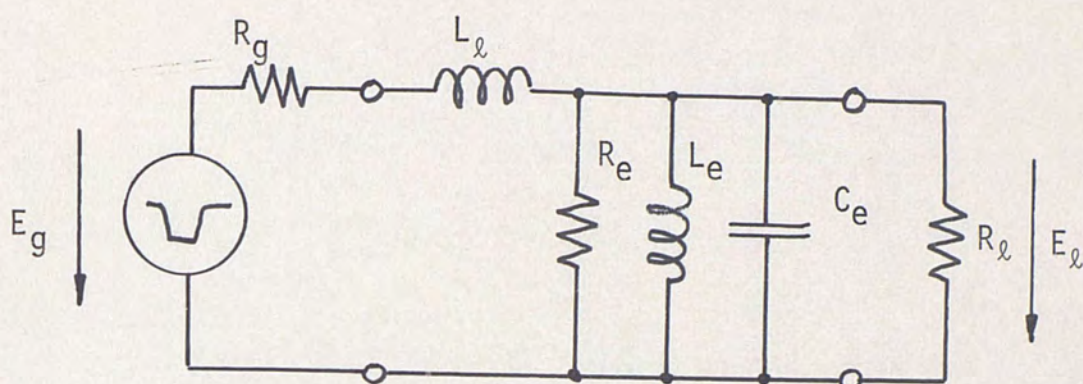

Figure 9. Equivalent Circuit for Top of Pulse

Since  $R_g$  is larger than zero,  $L_e$  will introduce a pulse decay with a time constant of

$$\tau = \frac{L_e (R_g + R_l)}{R_g R_l}$$

The nonlinear load will make this decay much more evident in the current pulse through the load than in the voltage across it. The current pulse is important since it is equivalent in shape to the envelope of the RF pulse emitted by the magnetron.

$C_e$  and  $L_e$  will introduce some ringing to the pulse, again much more visible on the current pulse, but the low value of  $R_l$  will make this ringing decay with an exponential function of time constant  $\tau_1$ .

$$\tau_1 = 2 \frac{L_e}{R_l}$$

The tail and backswing of the pulse is determined by the amount of energy stored in  $L_e$ . The magnetic field in  $L_e$  is represented by the flux density  $B$  in Figure 10. The energy stored in the magnetic field of the transformer is equal to

$$E = \frac{1}{2} L_e I_{\max}^2$$

where  $I_{\max}$  is the current through  $L_e$  at the end of the pulse. The magnetic field that is building up during the pulse has to return from its maximum value,  $B_{\max}$ , to a minimum value of  $B_{\min}$  during the interpulse period. This change in flux will induce a voltage inverse to the pulse polarity. The energy stored in the magnetic field has to be dissipated during the pulse interval making the stored energy important to the efficiency of the pulse transformer. The equivalent circuit for this time period is shown in Figure 10c.

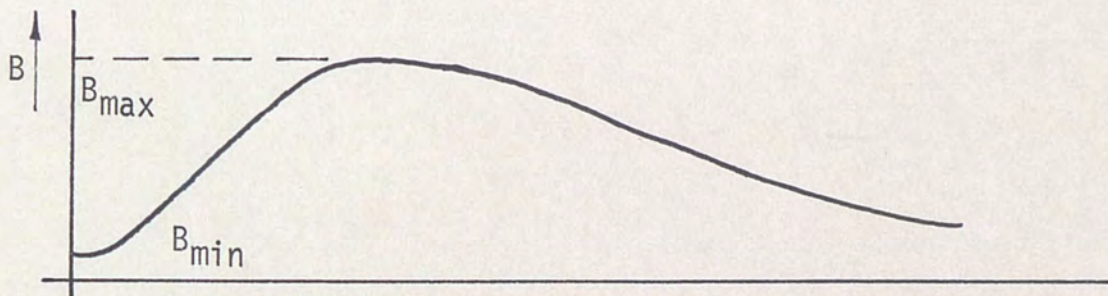

Figure 10a. Magnetic Field in Transformer Core

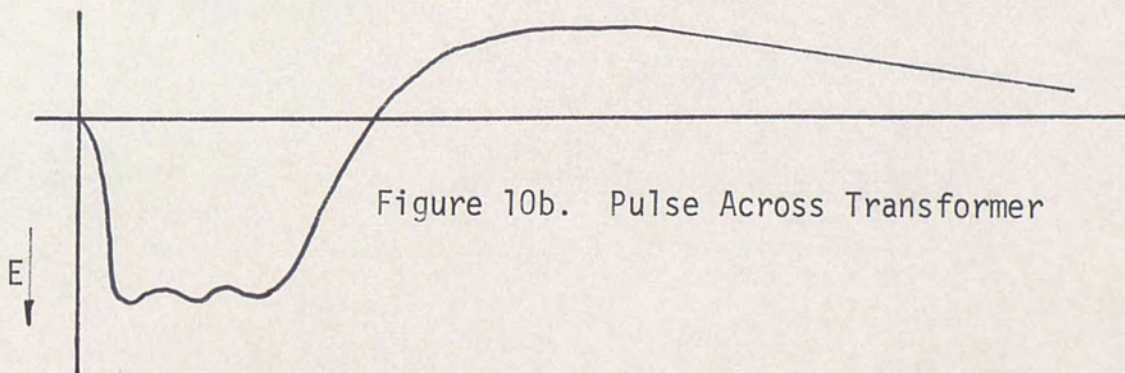

Figure 10b. Pulse Across Transformer

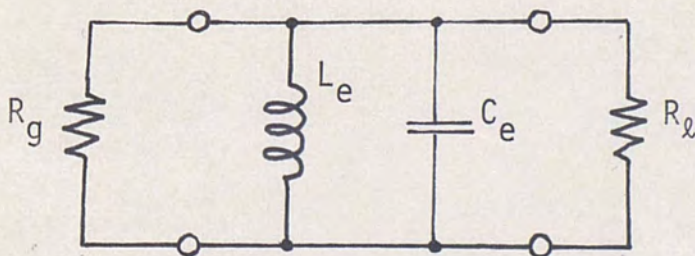

Figure 10c. Equivalent Circuit for Fail and Back Swing of Pulse.

$L_e$  and  $C_e$  form a ringing circuit that is damped by  $R_g$ .  
 $R_\ell$  can again be neglected since it is large compared with  $R_g$ .

## 2.2 PULSE TRANSFORMER

In Chapter 1, it is mentioned that a step-up ratio of 1 to 20 is considered the optimum value for this transformer using a hypersil\* core. The core that is used was chosen after approximately a dozen different design tries using different cores. The following parameters had to be met.

1. Secondary maximum voltage, 13kV under fault condition.
2. Maximum voltage gradient in insulation, 80V/mil for nominal operation.
3. Rise time with resistive load, 100-300 ns.
4. Fall time with resistive load less than 1us.
5. Overshoot, less than 15%.
6. Secondary copper resistance total of 1 ohm at 25°C, each winding .5 ohms.
7. Primary copper resistance less than 30m ohms.
8. Core must saturate with 500V applied after approximately 5us.
9. Magnetization current after 3.5us with 250V applied must be less than 20A.

In the first step in the design of the transformer only tape wound C-core are considered. They are the easiest to assemble. Torroidal cores will give the highest permeability, however, they are very difficult to wind especially if large wire sizes are involved. Further, the uniform application of insulation material on torroidal cores is nearly impossible.

\*Hypersil--trade name for grain oriented transformer lamination.

From the Massachusetts Institute of Technology Handbook, Pulse Generators<sup>1</sup>, a certain winding or interleaving pattern is chosen to give the strongest coupling between primary and secondary winding. Figure 11 shows this pattern.

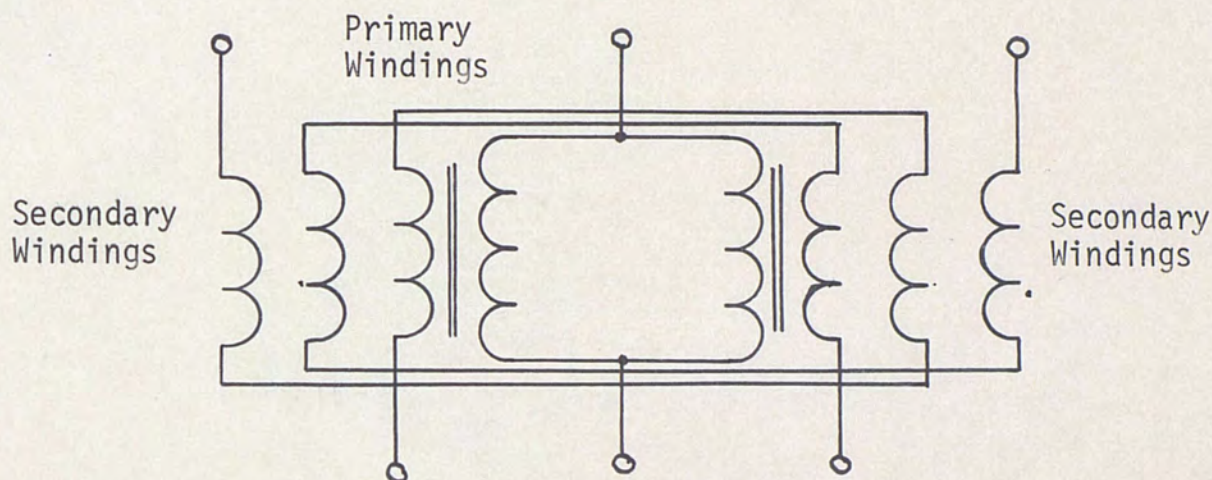

Figure 11. Winding Pattern

This winding configuration gives some information about the core to be used. Each secondary layer has approximately

$$\frac{1\Omega}{6 \text{ layers}} = .18\Omega/\text{layer}$$

of copper resistance since, as mentioned in Chapter 1, both secondary windings are used as series resistors to the magnetron filament.

The transformer will be placed on each of the two legs of the C-core. This makes it necessary to have, as closely as possible, the same number of turns on both primary windings. An experiment showed that the closest tolerance possible for production was

<sup>1</sup>G. Norris Glascoe and J. V. Lebacqz, Pulse Generators, Massachusetts Institute of Technology Radiation Laboratory Series (Lexington, Mass.: Boston Technical Publishers, Inc., 1964), p. 518.

$\pm .25$  turns. Therefore, six turns are chosen as minimum for the primary winding.

The maximum magnetization current is then used to figure the minimum inductance six turns should give on a certain core:

$$L_{\min} = \frac{250V \times 3.5\mu s}{20A} = 43\mu H$$

An air gap has to be considered in this calculation. The air gap is necessary to increase the uniformity between different batches of cores. Since the transformer is to be used in a single-sided pulse application, the residual magnetism after each pulse recurrence ( $B_{\min}$ ) is of importance. A reduction of inductance through an air gap will reduce the remanance by approximately the same ratio.

The maximum voltage between two secondary layers of the nominal pulse is

$$\frac{2}{3} \times 5kV = 3.3kV$$

After several experiments, 5mil Kraft paper is chosen as insulation material because of its porosity and its ability to absorb impregnating compounds. From the voltage gradient and the maximum voltage between layers, the required insulation space is found:

$$\frac{3.3kV}{80V/mil} = 41mil \text{ per layer}$$

This requires eight wraps of 5mil Kraft paper between layers.

A "dry transformer" is pictured in Figure 12. The term "dry transformer" implies a wound specimen that is not yet impreg-

nated and potted. A single step impregnating and potting procedure was developed utilizing a semi-rigid epoxy.\*

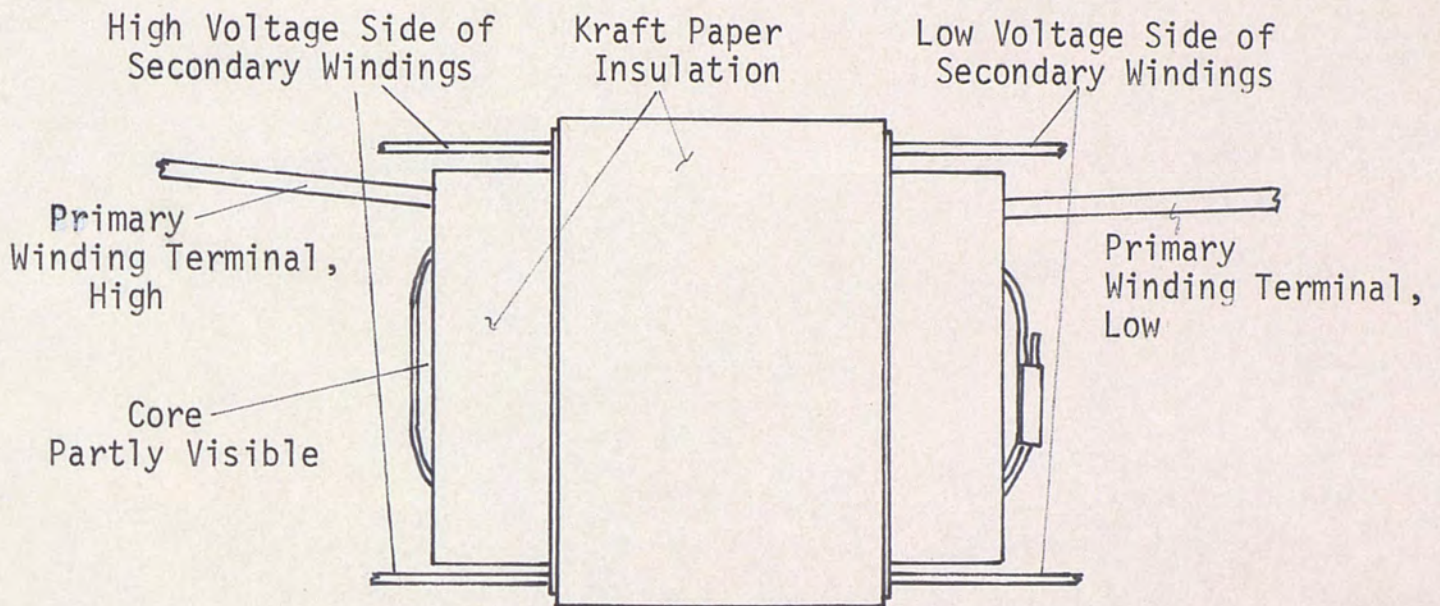

Figure 12. Pulse Transformer (Actual Size)

Corona is a most important factor with any high voltage component. Corona,<sup>2</sup> if present, will slowly destroy any type of solid insulation through several different mechanisms. Briefly, corona constitutes a periodic electrical discharge. Commonly, corona occurs if microscopic gas enclosures are present in the insulation material.

Some frequencies of the corona frequency spectrum extend into the HF and VHF range. It is, therefore, convenient to use the high frequency range of the corona spectrum to indicate the presence of corona. To test each unit for corona, the following test circuit was chosen. See Figure 13.

\*Scotch Cast 431, 3-M Company.

<sup>2</sup>E. Kuffel and M. Abdullah, High-Voltage Engineering (New York: Pergamon Press, Ltd., 1966), Chapters 2 and 3.



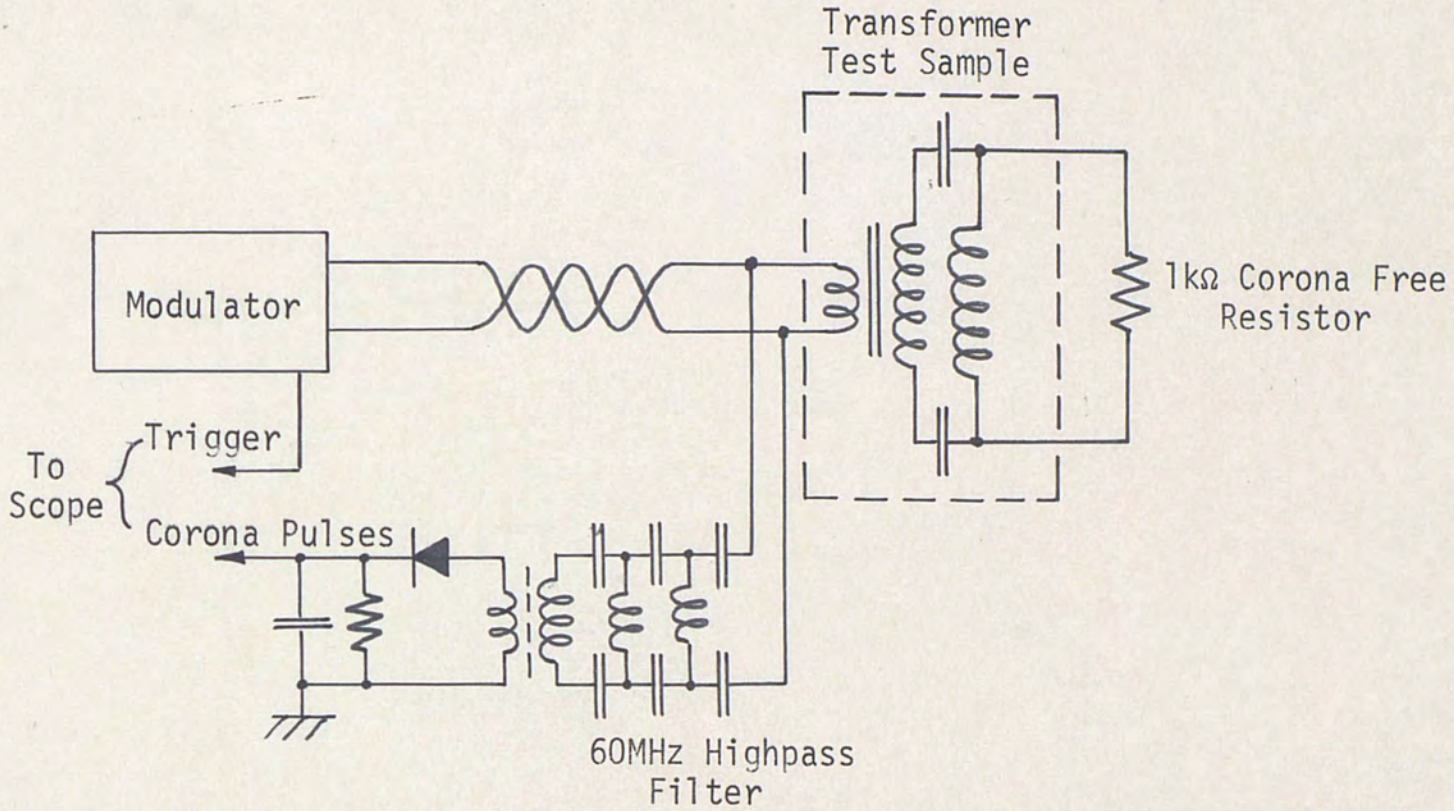

Figure 13. Corona Test Circuit

The corona test circuit is not considered to be an accurate calibrated indicator of corona but merely an indicator of the presence of corona. It consists of a symmetrical high-pass filter with a cutoff frequency of 60MHz that is connected across the primary winding of the pulse transformer.

Several transformers were tested with this circuit and showed a definite "corona onset" point at 9 to 12kV of pulse voltage across the secondary winding. This is well above the operating voltage of 5kV.

### 2.3 THE PULSE-FORMING NETWORK

As discussed in Chapter 1, a lumped-element delay line is used to generate the pulse. A lumped line is made up of a cascade of symmetrical networks such as the T-section of Figure 14.

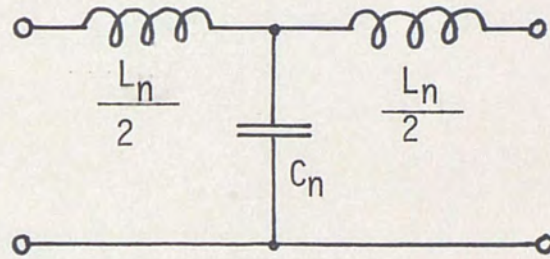

Figure 14. T-Section of Delay Line

The quantity  $\sqrt{L_n C_n}$  represents the delay time per section; therefore, an  $n$ -section line, when used as a pulse-forming network, will produce a pulse of duration  $\tau$  if all sections are equal.

$$\tau = 2n \sqrt{L_n C_n}$$

The cutoff frequency of one section is approximated by

$$f_c = \frac{1}{2\pi \sqrt{L_n C_n}}$$

The rise time of the pulse is determined mainly by the first L-C-section. For an equal section delay line, the first inductor is equal to  $L_n/2$ . This gives an expression for the rise time  $T_r$ .

$$T_r \approx \frac{1}{10 f_c}$$

The number of sections necessary to achieve a rise time of 150ns

is then given by

$$n = \frac{\pi \tau}{10 T_r} = \frac{\pi \times 3.5 \mu\text{s}}{1.5 \mu\text{s}} = 7.3$$

The total capacitance of the network has to store the energy required for each pulse. This energy is

$$E = V \times I \times \tau = 250\text{V} \times 100\text{A} \times 3.5 \mu\text{s} = .0875\text{Ws}$$

The stored energy in a capacitor is

$$E = \frac{1}{2} CV^2$$

this determines the total capacitance of the network

$$C = \frac{2E}{V^2} = \frac{.175}{.25} 10^{-6}\text{F} = .68 \mu\text{F}$$

$$C_n = \frac{.68}{7} \mu\text{F} = .097 \mu\text{F}$$

The capacitor  $C_n$  of each section is  $.097 \mu\text{F}$ . The inductance  $L_n$  between each capacitor is determined with

$$L_n = \left( \frac{\tau}{2n} \right)^2 \frac{1}{C_n} = .52 \mu\text{H}$$

This does not include losses. The transformer is assumed to have an efficiency of 95%. The pulse-forming network is estimated with 85% efficiency making the total efficiency approximately 80%. This power loss has to be compensated with an increased storage of energy. The capacitance of each line section is

chosen with

$$C_n = \frac{.097\mu\text{F}}{.8} = .12\mu\text{F}$$

In the previous section, the primary impedance of the pulse transformer was determined with  $2.5\Omega$ . The characteristic impedance of the line will be approximately of the same value. Slight mismatches will not affect the power transfer to any great extent as Figure 15 shows.  $\eta$  is the ratio of power into any load resistance  $R_\ell$  to the power into a matched load  $Z_o$ .

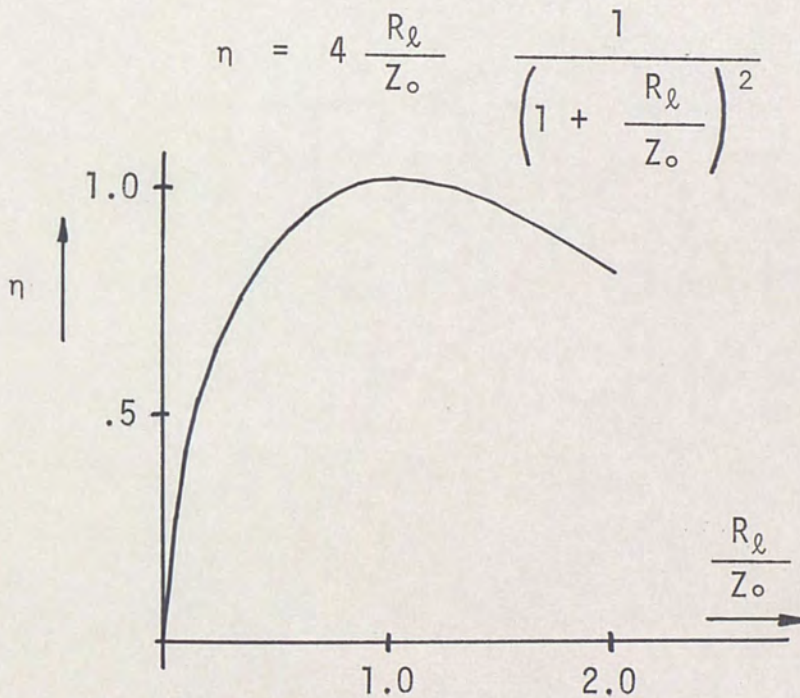

Figure 15. Power Transfer Efficiency

The capacitors have to withstand large current surges; therefore, foil wrapped capacitors are chosen for the pulse-forming network. The current in each one of the capacitors are approximated in Figure 16 for a four-section network. It is shown there that the last capacitor in the line has the largest pulse, the highest stress, and would be the first one to fail.

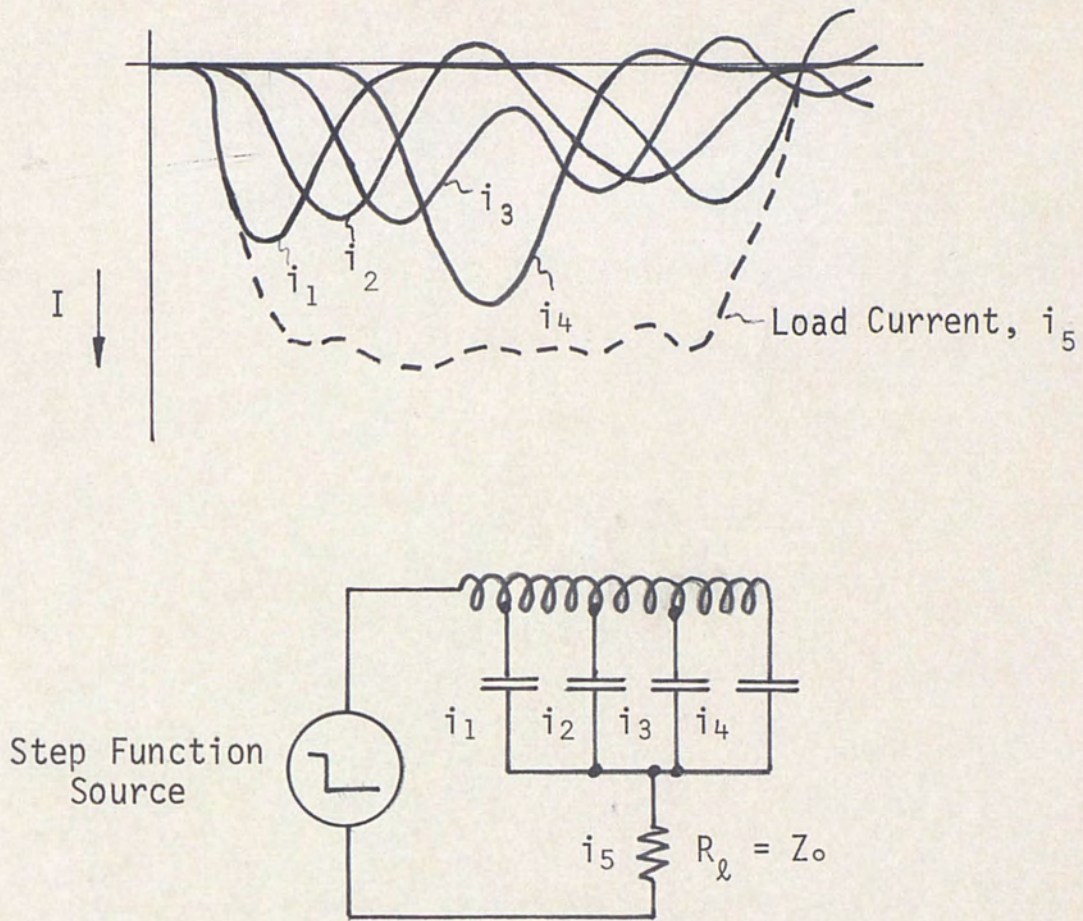

Figure 16. Capacitor Currents in Four-Section Pulse-Forming Network

## 2.4 SWITCHING CIRCUIT

As previously mentioned, an SCR was chosen as a switching device. However, the SCR is too slow to achieve the desired rise time. Furthermore, the instantaneous dissipation is barely in the limits of the device. The efficiency is low since approximately 30 percent of the energy available from the pulse-forming network is dissipated in the SCR.

This makes a secondary switching device necessary. A saturable choke is used for this purpose. From Figure 17, it is concluded that the choke should saturate at approximately  $1.5\mu\text{s}$  after the SCR initially starts to conduct.  $1.5\mu\text{s}$  is a sufficient delay to make the SCR conduct. Furthermore, the choke had to saturate at a current level of approximately 5A so that minimum energy would leak out of the pulse-forming network. The initial current through the SCR before the choke saturates is called the priming current.

Using a torroidal core for the saturable choke and assuming a uniform current sheet around that core, the saturated inductance of the core will be

$$L_S = \frac{\mu_0 N^2}{l} A (\epsilon \mu_S - \epsilon + 1)$$

$L_S$  = Saturated Inductance

$A$  = An Area Enclosed by a Turn

$l$  = Mean Magnetic Path Length

$N$  = Number of Turns

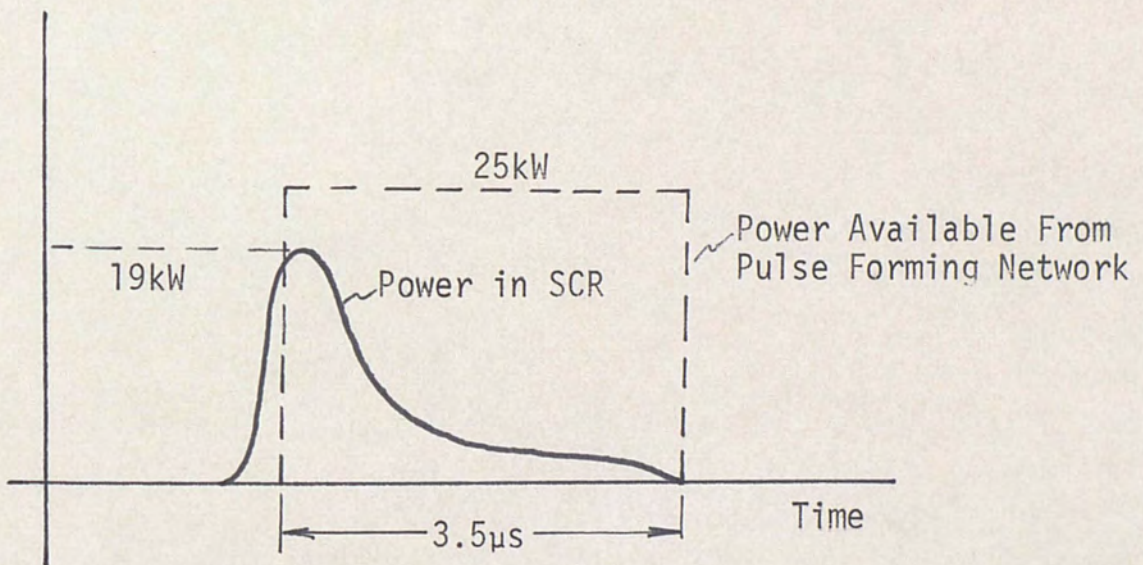
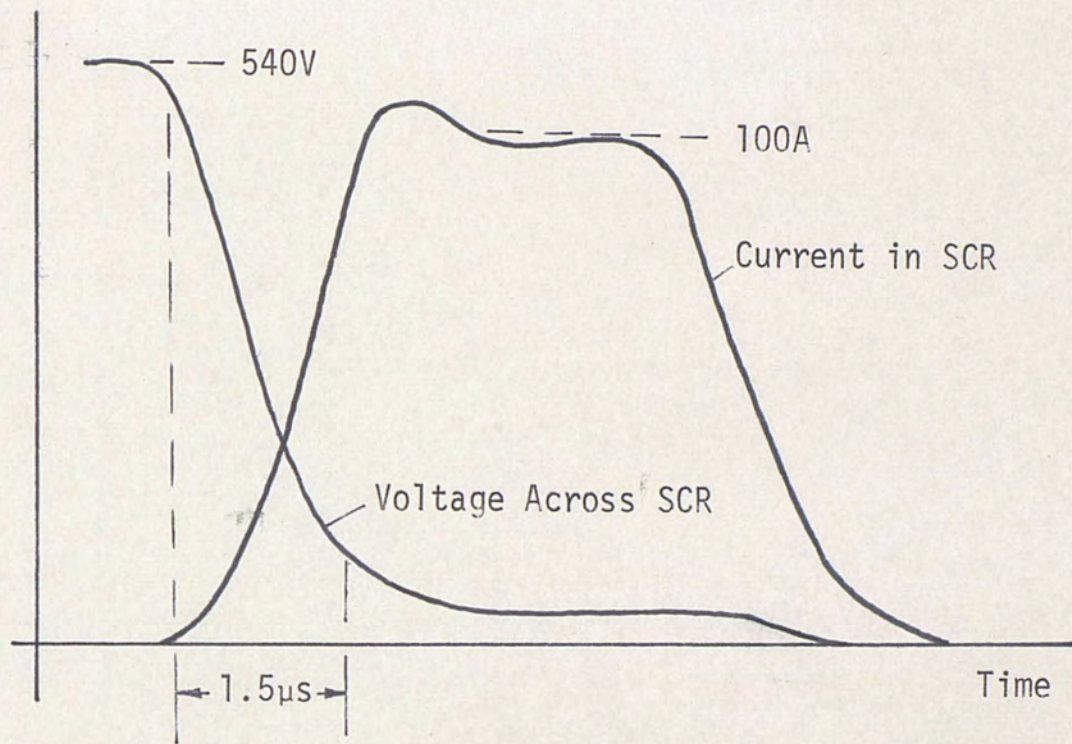

Figure 17. Power Dissipation in Main Switching SCR, No Delay Reactor

The time to saturation will be governed by the following law:

$$E \times t_p = \Delta B \times \alpha \times N$$

$E$  = Applied Voltage

$t_p$  = Time to Saturation, Priming Time

$\alpha$  = Effective Core Area, Iron Area

Assuming the rise time of the modulator pulse to be

$$t_r = 2.2 \frac{L'_s}{R_\ell + Z_n}$$

where

$$R_\ell = Z_n$$

$L'_s$  = Total Inductance in Pulse Loop

$R_\ell$  = Load Resistance

$Z_n$  = Pulse-Forming Network Impedance

Since  $t_r$  had to be in range from 100 to 300  $\mu$ s, a formula for  $t_r$  had to be found.<sup>3</sup>

$$t_r = 1.1 \mu_o \left( \mu_s - 1 + \frac{1}{\epsilon} \right) \frac{W}{\alpha \ell} \left( \frac{t_p}{\Delta B} \right)^2$$

$$t_r = \frac{(\text{composite permeability}) (\text{peak power in load}) (\text{priming time})^2}{(\text{core volume}) (\text{available flux density charge})^2}$$

The priming choke chosen has 19 turns of AWG #18 on Magnetics, Inc. 50002-1A core. The delay obtained is 1  $\mu$ s with 540V on the pulse forming network.

<sup>3</sup>T. H. Robinson, "Circuit Configuration and Thyristor Rating for Solid-State Modulators," Proceedings of the Tenth Modulatory Symposium, 1968.



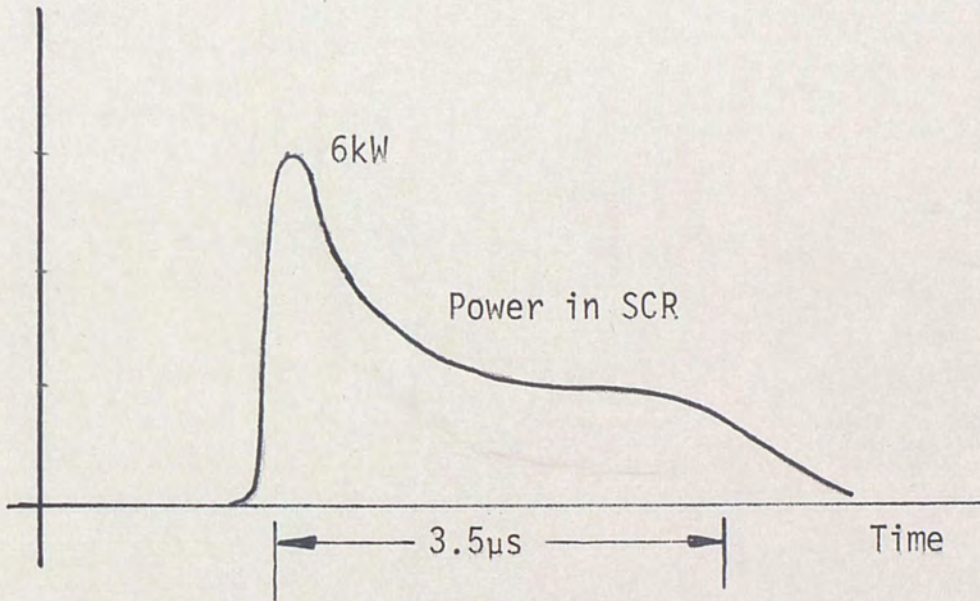
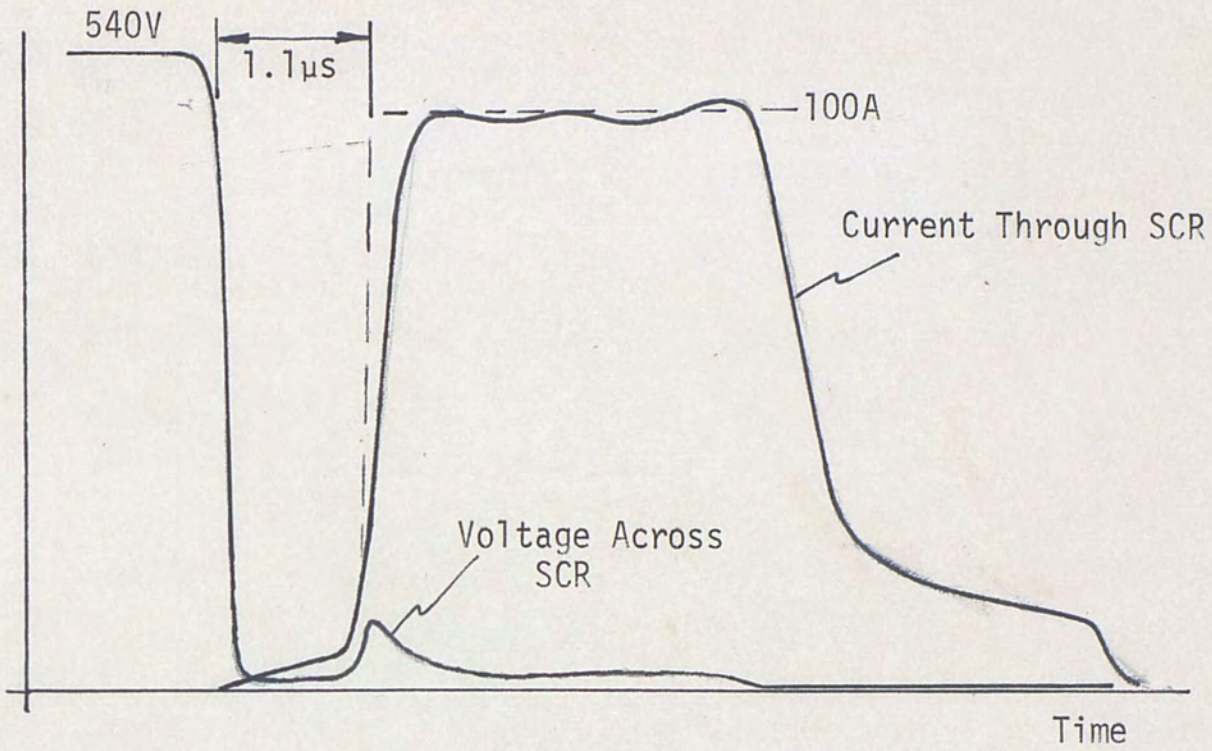

Figure 18. Power Dissipation in Main SCR with Delay Reactor

The introduction of the delay reactor in series with the main switching SCR reduces the power dissipated in the device by a factor of 10. Figure 18 shows the instantaneous dissipation in the SCR during each pulse.

## 2.5 CHARGING CIRCUIT

Although the charging circuitry has very little effect on the output pulse of the modulator, the design of the circuitry and the choice of the components is important to the over-all efficiency.

The charging circuit must isolate the power supply from the main switching SCR during and shortly after the pulse. Furthermore, the charging circuit must spread the recharge of the pulse-forming network over as much time as possible, and still fully recharge the network before the next pulse is developed.

Resonant charging is used for this modulator. Figure 19 shows the simplified diagram.

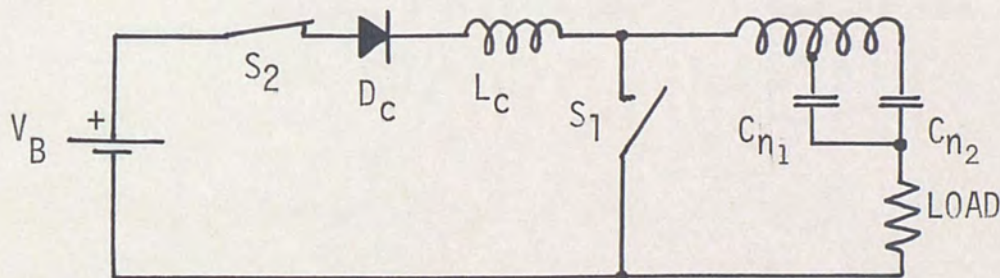

Figure 19. Resonant Charging Circuit

The inductance of the pulse-forming network is neglected since its value is small compared to the inductance of the recharge coil,  $L_C$ . When switch  $S_2$  closes,  $L_C$  and  $C_n$  will combine, forming a resonant circuit. The voltage rise on  $C_n$  will be as high as  $2V_B$  depending on the value of the total series resistance of the charging loop,  $R_C$ . Since the hold-off diode  $D_C$  prevents a reversal of the charging current, the maximum voltage will remain on the pulse-forming network until  $S_1$  closes.

Since the pulse repetition rate of the modulator is approximately 100 pulses per second, the value of  $L_c$  is defined by

$$L_c \leq \frac{T^2}{4\pi^2 C_n} = 4.7H$$

where

$T$  = Pulse Interval

$C_n$  = Total Pulse-Forming Network Capacitance

$L_c$  is chosen with 3H.

### 3.1 SUMMARY AND CONCLUSIONS

The preceding chapters show how the modulator was designed. By the time this report was written, production quantities of modulators were built and incorporated into the radar systems.

The modulators, up to this time, performed well and reliably. However, there is an area that can be improved: The relay that is used to prevent a latch-up should be replaced by a solid-state circuit.

A new circuit is under investigation that combines the functions of the relay and the control SCR ( $S_2$ ) in one transistor switching stage. Photo optical couplers will be used to drive the transistor switch.

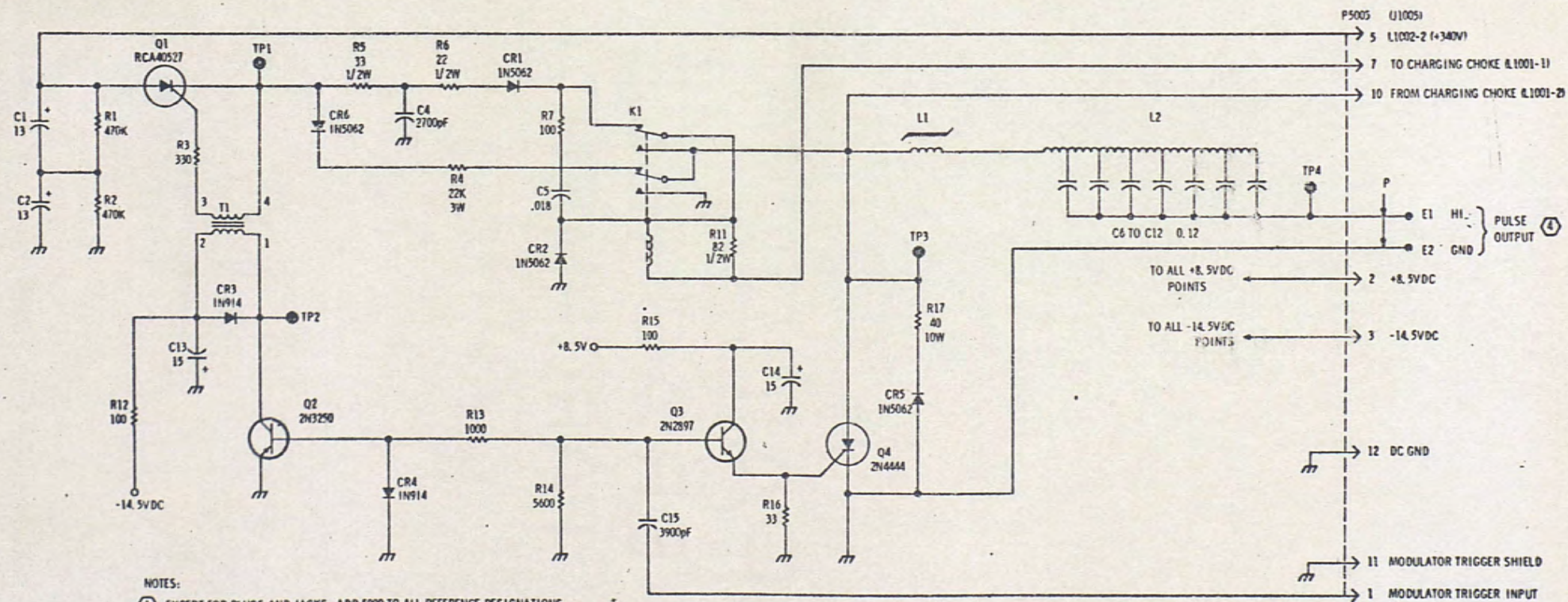

NOTES:

- ① EXCEPT FOR PLUGS AND JACKS, ADD 5000 TO ALL REFERENCE DESIGNATIONS.
- ② ALL RESISTANCE IN OHMS; CAPACITANCE IN MICROFARADS UNLESS OTHERWISE SPECIFIED.
- ③ ALL RESISTORS 1/4 WATT UNLESS OTHERWISE SPECIFIED.
- ④ E1 AND E2 ARE SOLDER TERMINALS ON THE BOTTOM OF THE CIRCUIT BOARD.

4000572A

Figure A-1. Schematic of Modulator Printed Circuit Board

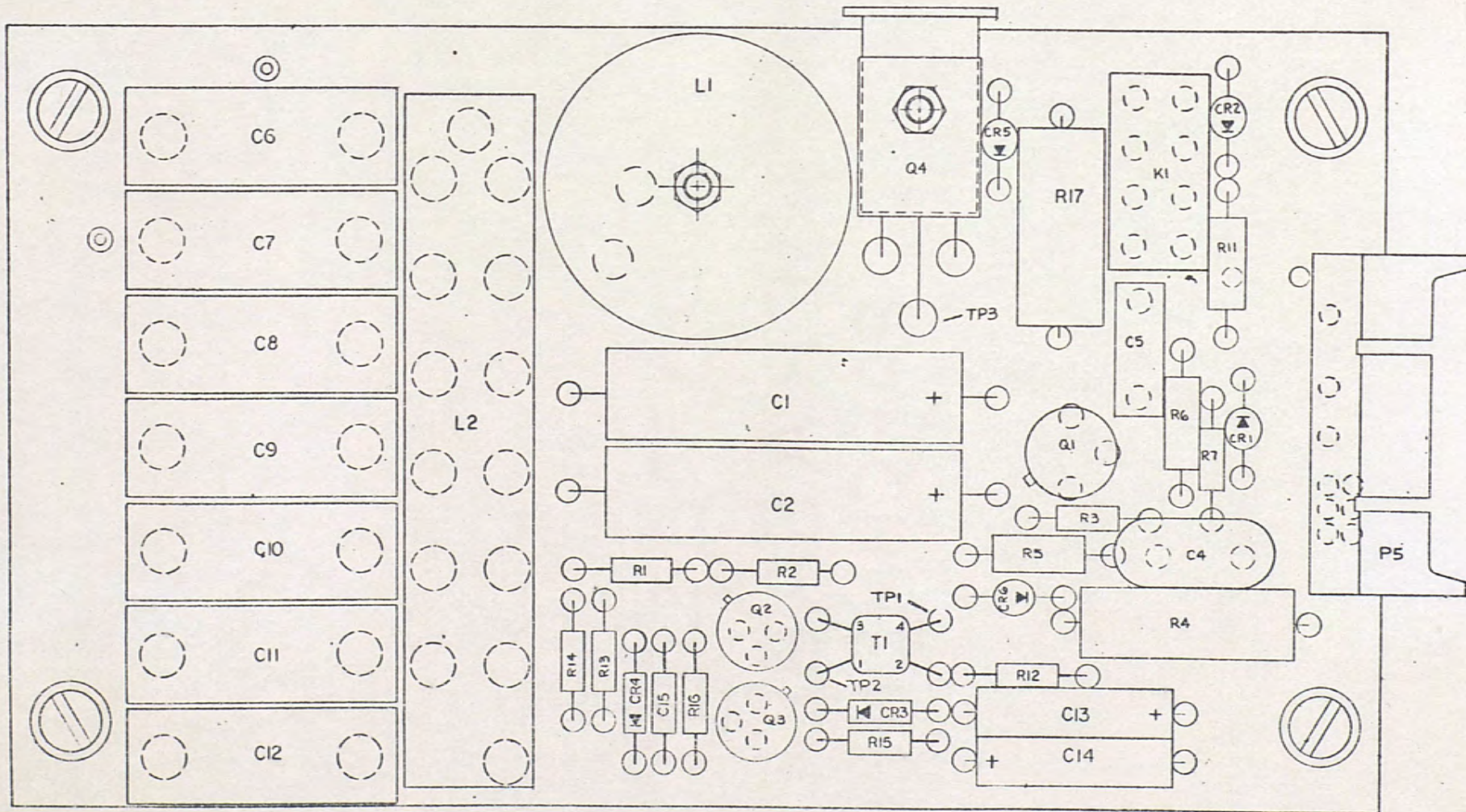

Figure A-2. Printed Circuit Board Layout

## BIBLIOGRAPHY

- COLLINS, George B. Microwave Magnetrons, MIT Radiation Laboratory Series. Lexington, Massachusetts: Boston Technical Publishers, Inc., 1964.
- GLASCOE, G. Norris, and LEBACQZ, J. V. Pulse Generators, MIT Radiation Laboratory Series. Lexington, Massachusetts: Boston Technical Publishers, Inc., 1964.
- INGEGNERI, Anthony R. "A Pulse Modulator Using High Power Step/Recovery Diodes," Proceedings of the Tenth Modulatory Symposium. New York, 1968.
- KUFFEL, E., and ABDULLAH, M. High-Voltage Engineering. New York: Pergamon Press, Ltd., 1966.
- ROBINSON, T. H. "Circuit Configuration and Thyristor Rating for Solid-State Modulators," Proceedings of the Tenth Modulatory Symposium. New York, 1968.
- WESTINGHOUSE ELECTRIC CORPORATION. "Interim Development Report for Modular Solid-State Modulator Development," 13 October 1969 to 2 January 1970, Navy Contract N00039-70-C-1506, Project XF-5254007, Task 8089. January, 1970.
- WESTMAN, H. P., ed. Reference Data for Radio Engineers. 5th ed. New York: Howard Sams & Company, Inc., 1969.