



An Amateur Radio publication for the Microwave Enthusiast

scatterpoint

Formerly the RSGB Microwave Newsletter and now published by the UK Microwave Group

2007 NOVEMBER-DECEMBER

Number One Microwaver

Ralph Bird, G4ALY (on the right in the photo here) becomes the first UK microwaver to receive the G3EEZ Memorial Award for outstanding contributions to Amateur Microwave Communication. He was presented with this magnificent cup by RSGB President Angus Annan, MM1CCR, at the Martlesham Microwave Round Table in mid November.

There is more on this and the Round Table in this month's Scatterpoint.



In this issue ...

- GB3CAM .. Cambridge Repeater
- A 2.3GHz LNA ... by G4DDK
- Martlesham Report... photos, business and individual reports
- Transitions for Small Waveguides... by W1GHZ
- Contest Activity .. A review by G4EAT
- Two new Microwave Round Table venues for 2008
- Notes from the RSGB Microwave Manager ... G6JYB
- Activity News
- For Sale Ads
- Online Microwave Museum

Latest News ...

- **Martlesham Round Table a great success**
- **G4ALY receives the Alan Wakeman (G3EEZ) Award**
- **Survey reveals decline in /P microwaving in UK**
- **Two new Microwave Round Table meetings planned for 2008**

Scatterpoint Editorial Panel

Editor: Peter G3PHO

Activity News: Robin G8APZ

Technical Editor: John G4BAO (from Jan 2008)

UK Microwave Group Contact Information

<p>Chairman: G4NNS Brian Coleman</p> <p>Email: chairman@microwavers.org</p> <p>Located: NearAndover(I091FF)</p> <p>Address: Woodlands, Redenham, Andover, Hants., SP11 9AN</p> <p>Home Tel: -</p>	<p>Secretary: G8KQW Ian Lamb</p> <p>Email: secretary@microwavers.org</p> <p>Located: Hindhead, Surrey</p> <p>Address: Little Court, Churt Road, Hindhead, Surrey GU26 6PD, United Kingdom</p> <p>Home Tel: ++ 44 (0)1428 608844</p>	<p>Treasurer: G4FSG Graham Murchie</p> <p>Email: treasurer@microwavers.org</p> <p>Located: Woodbridge(J002)</p> <p>Address: 42 Catherine Road, Woodbridge, Suffolk, IP12 4JP</p> <p>Home Tel: -</p>	<p>Scatterpoint Editor: G3PHO, Peter Day</p> <p>Email: editor@microwavers.org</p> <p>Located: Sheffield (I093GJ)</p> <p>Address: 146 Springvale Road, Sheffield, S6 3NU, United Kingdom</p> <p>Home Tel: ++ 44 (0)114 2816701 (after 6pm)</p>
---	---	---	--

From the Editor's Desk



Seasons Greetings to all our readers!

This issue was so tight on space that we have had to add four extra pages and even then we've not got enough room for everything we want to include! However, all that will all appear next month.

A lot is happening on the Ofcom and IARU front so, to keep up with the news, we recommend you check the UKuG website on a regular basis. There you'll find links pointing to the "radio politic" items that Murray, G6JYB, our RSGB Microwave Manager, flags up from time to time.

Martlesham was a huge success. I really enjoyed it and think it was possibly the best one ever. Four out of the seven talks were given by overseas speakers and we thank them very much indeed for their services. Sadly, I missed Henning DF6IC's lecture on aircraft scatter but I was captivated by Jens SM6AFV's talk on remote station operation. If you saw my own QTH you'd realise why! Zdenek, OK1DFC, kept us all enthralled with a video illustrated account of the erection of his homebrew 11 metre dish antenna. It used over 10,000 rivets in its assembly! Before that, Rainer, DF6NA, gave a very interesting account of the German uW beacon situation. It seems the DLs also have problems (and we thought only the UK had those...).

Finally, our congrats go to Ralph, G4ALY, who is the first proud recipient of our new G3EEZ Memorial Award for Contributions to Microwave Communications. Ralph is known as the "Beacon of the South West" as he's the only really active operator in the Devon/Cornwall region. His recent "First" QSOs between the UK and Spain (see last month's Scatterpoint) are a measure of the dedication and expertise he has shown over many years. He's also a really nice guy...

73 from Peter, G3PHO
Editor



G3PHO: editor@microwavers.org



G3PHO: Peter Day ++44 (0)114 2816701



G3PHO, Peter Day,
146 Springvale Road,
Sheffield, S6 3NU, UK

News, views and articles for this newsletter are always welcome. Please send them to G3PHO (preferably by email) to the address shown lower left. **The closing date is the Friday at the end of the first full week of the month** if you want your material to be published in the next issue.

UKuG MEMBERSHIP RATES INCREASE

The UKuG Committee has just agreed upon a small increase in membership fees which will apply to new members and renewals from 01/01/2008 onwards. This is due to increased printing and postage costs incurred with the paper version of Scatterpoint. The increases do NOT affect members joining at the basic rate and receiving an email (PDF) Scatterpoint only. The basic membership remains at £6 Sterling or equivalent in US Dollars or Euros. The increase applies only to members who ask for a printed newsletter. The new, inclusive rates are:

	GBP	USD	Euro
UK	14	-	-
EU	18	36	26
RoW	24	48	36

HAVE YOU RENEWED YOUR UKuG SUBSCRIPTION YET? YOU CAN CHECK THE RENEWAL DATE ON YOUR ENVELOPE ADDRESS LABEL IF YOU RECEIVE A PRINTED SCATTERPOINT. THE DATE IS ON THE LOWER RIGHT CORNER OF THE LABEL. IF YOU STILL DON'T KNOW YOUR RENEWAL DATE PLEASE EMAIL THE SECRETARY, G8KQW, AS SOON AS POSSIBLE!

SUBSCRIPTION ENQUIRIES SHOULD BE SENT TO THE UKuG GROUP SECRETARY AT THE ADDRESS SHOWN AT THE TOP OF THIS PAGE

GB3CAM

3cm

Cambridge Beacon

Here are a few more details about GB3CAM, the Cambridge 3cm beacon on 10 368.750 MHz, which is currently being tested using the callsign G4AKD/B and temporarily located at Dry Drayton (4m to the west of Cambridge).

About two years ago, knowing that there was 10GHz activity within the Cambridge and District ARC membership, the Cambridge Repeater Group asked if the CDARC would be interested in producing and owning a beacon that the repeater group would host at either their Madingley or Barkway sites. There had been a WB beacon at the club premises at the Coleridge Community College for many years and this had only recently been removed because of repair work to the college building. The radio club was enthusiastic about the offer, which it saw it as an opportunity to rekindle interest in the band and also provide a frequency reference, given that operation to date had been WB, using cavity or puck controlled frequency sources. At about this time, Sam (G4DDK) was working in Cambridge and was quite independently generating interest in a beacon located on the company premises on the St John's Innovation centre. Roger (G4BEL), John (G4BAO) and myself were already active on narrowband, and most weeks had pub meals with Sam when he stayed over, so knew about both plans. When all this came out at a club visit some time later, I was asked if I was interested in being involved in the CDARC project, which I certainly was. With such good sites on offer from the CRG, the Innovation centre idea was not taken any further.

Although Barkway is a higher site than Madingley, the latter is much closer to Cambridge, and can be guaranteed to put a big signal into the town. For the club, this makes it very useful for generating local enthusiasm, and should still provide good take offs over the full 360 degrees. Its current temporary location (JO02AF), less than a mile from the Madingley complex, gives unobstructed line-of-site coverage of the town, and is already resulting in local WB receivers being dusted down and re-powered, and Dave (G6KWA) and other club members are putting together a WB club project to keep that interest going. This is giving time to put together a narrowband project, which looks as though it will be a scrap-box receive only converter - enough to demonstrate the various intrigues of Doppler on the beacon.

Recovered from the WB beacon was its dual 14 slot waveguide antenna (shown upper right), complete with wings, and ex-navy faring, still showing the many shrapnel marks of a very active service life.

Both were in good condition, so were re-used. A waveguide to sma transition was built and tuning screws added to obtain a good match, and a substantial aluminium base-plate produced with its own lower faring to waterproof the coax feedline connection. For the new beacon, all active circuitry is housed at ground level, and a power amplifier added to overcome the predicted 13dB feeder loss. This may seem a bit wasteful, but the repeater group site is now owned by Arqiva, and obtaining permission to do any mast work is no longer trivial. During current testing, no amplifier is fitted, so a short 3m feed run

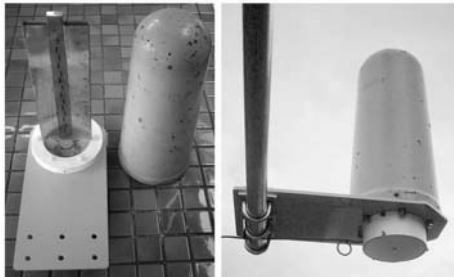

has been used to keep the feeder loss down to 3 dB, resulting in 0.5W at the antenna.

Two beacon drive units have been produced. They are pretty much the same, using multiplication from a 27 MHz crystal oscillator in one case and 13.5 MHz in



the other. The oscillators are built into small die-cast boxes fitted with thermostatically controlled heaters to keep the assemblies at about 45 degrees C. These are then locked to a Racal 9420 5 MHz standard using the parallel load MC145151 PLL IC, giving a final frequency accuracy of about +/- 200 Hz. A series of x2 multipliers bring the frequency up to 864 MHz for this first of six (ex Philips FX5000) module castings.

The next two x2 multipliers use printed interdigital filters etched on Teconic RF-35 material, each driven by a saturated uPC1678 onboard mmic amplifier. An Avantec 20 dB gain block follows and completes the second module, which provides about 13 dBm at 3456 MHz. In the third module, a single stage GaAs fet tripler feeds a five section waveguide filter built to the N6CA design (see <http://www.ham-radio.com/n6ca/microwave/filters/10368-28bpf.html>).

Output at 3cm (following a 2 stage Grundig amplifier) is 13dBm. A 3 stage PA module culminates in an MGF2445A output device and gives 1W after the isolator.

Keying is based on the IK0WRB design that can be found on the web, with the software taken unmodified. The application is written in Italian, but it's easy enough to work out the various settings. Two-point modulation is used, so both the 5 MHz standard and the TCXO are modulated. Power input is at 24v DC, with the PSU module using a SMPU pcb taken from a Philips PRF10 Base Station to pre-regulate down to 14.5v. Linear 10v regulators then feed the various modules.

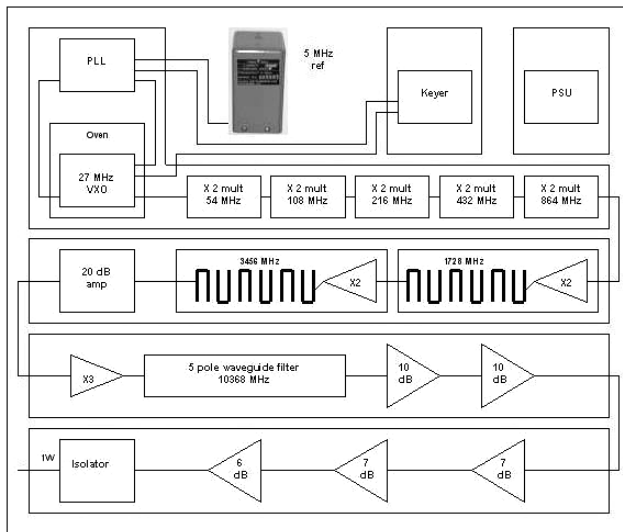

FROM THE RSGB MICROWAVE MANAGER ... Murray, G6JYB

2008 IARU Region-1 Conference in Cavtat, Croatia ...

As you read this the rush is on for submissions for the full IARU-R1 2008 conference. This is the opportunity to change policy within IARU if you feel change is needed (from contests logs to spectrum) or just write a good information paper. Contact Murray G6JYB (mjniman@iee.org) for microwave topics. Note that papers need to be reviewed by the RSGB Board before being submitted to the Region 1 Secretariat. Once all the papers are available there is expected to be a consultation phase later in the year prior to the conference itself in Cavtat in Nov-2008.

Yahoo group <http://uk.groups.yahoo.com/group/ukc5discussion/> covers chat on this topic.

2007 World Radio Communication Conference Geneva, Switzerland: 22 October-16 November 2007...

WRC-07 met in Geneva for four weeks to consider an agenda of 21 items unique to this conference and several standing agenda items. According to a provisional list of participants dated 12 November there were 2464 delegates from Member States and 294 participants from other organizations. In addition to a 7 strong IARU team, there were many other amateur radio national organisations represented including the RSGB, whose delegate was Colin Thomas, G3PSM.

Objectives of the IARU team included the defense of existing Amateur Service and Amateur-Satellite Service allocations as well as the preservation of access to the spectrum above 275GHz.

The identification of spectrum for expansion of International Mobile Telecommunications (IMT) was particularly contentious and was one of the last agenda

items decided at WRC-07. Attention was focused on modifying footnotes to designate some portions of the 2300-2400 MHz and 3400-4200 MHz bands for implementation of International Mobile Telecommunications (IMT) by administrations wishing to do so. The following footnotes were modified:

5.384A: The bands, or portions of the bands, 1710-1885 MHz, 2 00-2400 MHz and 2 500-2 690 MHz, are identified for use by administrations wishing to implement IMT in accordance with Resolution **223 (Rev.WRC-07)**. This identification does not preclude the use of these bands by any application of the services to which they are allocated and does not establish priority in the Radio Regulations. (WRC-07). [The band 2300-2400 MHz was added to this footnote.]

5.393: *Additional allocation:* in Canada, the United States, India and Mexico, the band 2 310-2 360 MHz is also allocated to the broadcasting-satellite service (sound) and complementary terrestrial sound broadcasting service on a primary basis. Such use is limited to digital audio broadcasting and is subject to the provisions of Resolution **528 (Rev.WRC-03)**, with the exception of *resolves* 3 in regard to the limitation on broadcasting-satellite systems in the upper 25 MHz. (WRC-07) [Canada was added to this footnote.]

5.394: In the United States, the use of the band 2 300-2 390 MHz by the aeronautical mobile service for telemetry has priority over other uses by the mobile services. In Canada, the use of the band 2 360-2 400 MHz by the aeronautical mobile service for telemetry has priority over other uses by the mobile services. (WRC-07)

[In the second sentence applying to Canada, the band was narrowed from 2300-2483.5 MHz.]

In addition, there were a number of new footnotes (not reproduced below) adopted that identified parts of the band 3400-3700 MHz for use by IMT by certain countries.



Low Noise Amplifier for the 2.3GHz band

Sam Jewell, G4DDK

Introduction

I have successfully modified the component values in my 23cm VLNA (see Scatterpoint September 07) to allow it to work on the 13cm (2320MHz) band. The results of my testing are that the prototype pre-amplifier is providing a measured noise figure of about 0.30 - 0.33dB with 25 - 26dB of insertion gain.

I have done additional testing over the frequency range 22250MHz to 2350MHz. In particular, I was interested in the LNA performance at 2250MHz as a possible pre-amplifier to use within the 2.2GHz Space Band. The performance of the unit, which was adjusted for lowest NF at 2320MHz, was maintained at 2250MHz.



Note: This is NOT a claim that this pre-amplifier will achieve this noise figure shown in the photo to the left. Accurate NF measurement is notoriously difficult to do and there are lots of pit-falls for the unwary. This picture shows a spot measurement I made whilst developing this LNA. But you must agree that it looks impressive!

The pre-amplifier uses the 23cm VLNA PCB with an Avago ATF36077 GaAs FET first stage into an ATF54143 second stage. It was necessary to re-calculate the noise match for the 36077 at 2320MHz as well as the interstage matching into the 54143 in order to achieve acceptable gain and overall

noise figure. Only the ATF36077, followed by an ATF54341 should be used in this pre-amplifier.

Commercial, silver-plated, plated-through-hole (PTH) PCBs and parts kits for the 13VLNA are available from the author. No connectors or feedthrough capacitors are offered, as with the existing 23cm VLNA. The kits contain the necessary components to make the 13cm version of the existing 23cm VLNA.

These pre-amplifiers are offered with the same tinsplate box housing as for the 23cm VLNA. When used with the supplied RF absorber tile, these amplifiers are unconditionally stable.

A limited number of 13LNA pre-amplifiers are available now. These use the original PCB as the new PCB version will not be available until early December. The 13LNA kit price will be the same as for the 23cm version.

Circuit description

The circuit schematic is shown on the next page

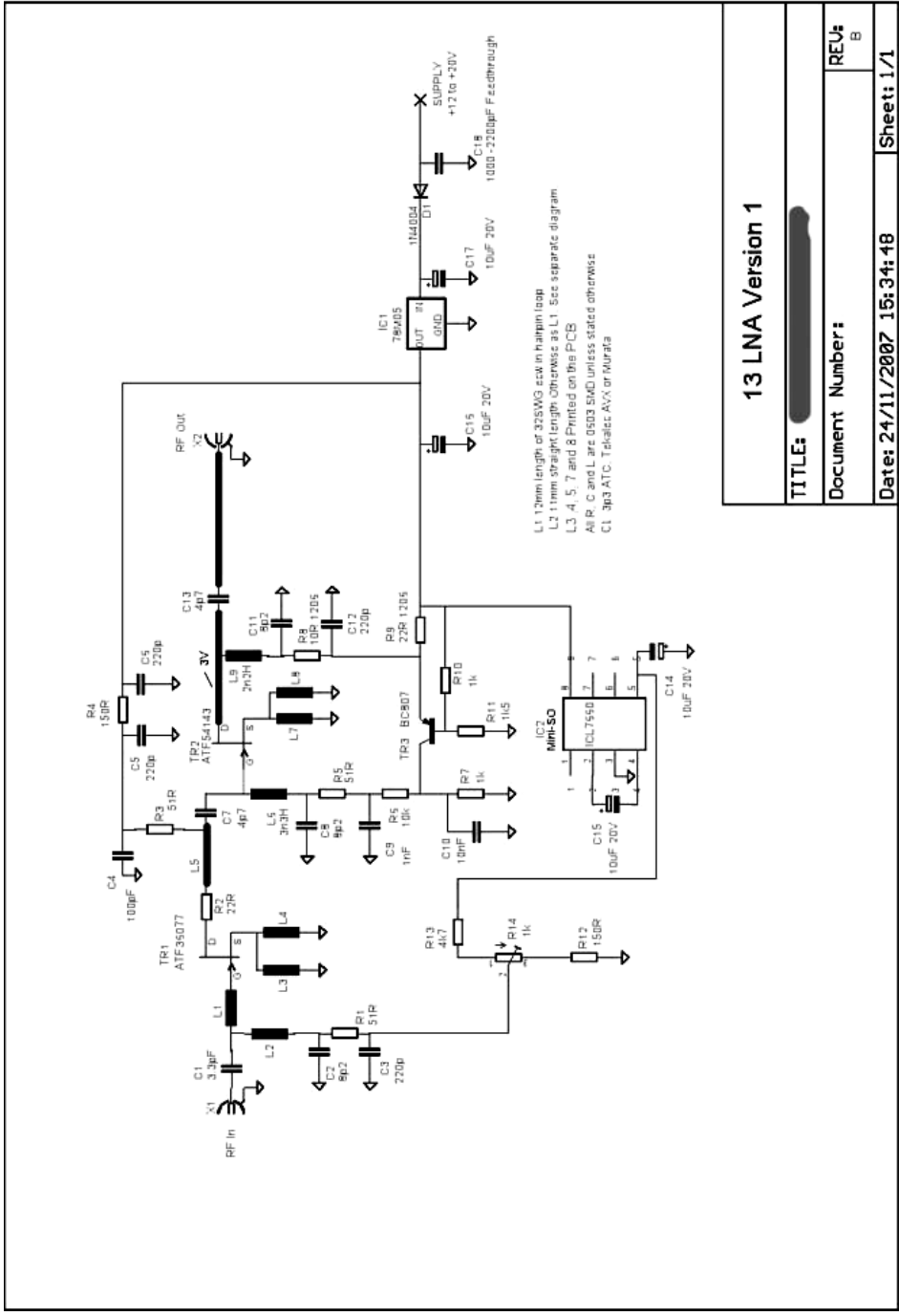

L1 12mm length of 325WG coax in hairpin loop
 L2 11mm straight length. Otherwise as L1. See separate diagram
 L3, 4, 5, 7 and 8 Printed on the PCB
 All R, C and L are 0503 SMD unless stated otherwise
 C1 3p3 ATC - Takeda AVX or Murata

13 LNA Version 1	
TITLE:	
Document Number:	
Date: 24/11/2007 15:34:48	Sheet: 1/1

The input circuit consists of a 'T' match with suitable low loss capacitor and inductors. **Photo 2** (right) shows the input arrangement. Low noise matching is achieved by adjusting the position of the hair-pin inductor, L1. The lowest noise figure occurs when L1 is at right angles to the FET.

Photo 2 Shows the input hairpin loop, L1, and the bias decouple, L2. The series input capacitor is 3.3pF.

Except where indicated, 0603 size surface mount components are used on the board in order to minimize component parasitics. This has proven most successful and it is a genuinely good reason to move towards 0603 or even 0402 size parts in all designs above 1GHz.

Negative bias for the ATF36077 is provided by an 7660 DC-DC inverter IC. R14 allows a range of adjustment, from approximately -0.4 to -1.2V. The bias adjustment range has been modified from the original 23cm VLNA. R13 has been changed to 4.7k and R12 has been decreased to 150R. R4, in the drain supply to Tr1, has been increased to 150R.

Active bias was chosen for Tr2 as the drain current is set quite high, at 60mA, to achieve a good dynamic range. At this elevated current I felt that active bias would help to maintain circuit performance. This is provided by Tr3, a BC807 PNP transistor .

The whole unit runs from a 5 volt, 500mA regulator IC that uses a surface mount (D-Pak) 78M05 regulator soldered to the PCB ground plane to act as the heat sink. A TO92 packaged 78L05 will not supply enough current without over-dissipating.

D1 is there to ensure that an accidental reversal of the supply doesn't destroy the pre-amplifier. The Trucap tantalum capacitors, especially C17, seem to be very sensitive to even small reverse voltages. If you do accidentally connect up the supply with reversed polarity, the preamp should survive, although C17 may need to be changed to ensure longer term reliability. This is probably true for many tantalum capacitor manufacturers.

The RF absorber material IS PART OF THE DESIGN and must be used if the full performance of the pre-amplifier is to be achieved.

Construction

The PCB is designed to fit into a popular 74 x 37 x 30mm tin plate box (see upper diagram on the next page). A revised PCB will be offered in the kit.

It is advisable to solder the four 10uF Tantalum capacitors, R14 and 78M05 voltage regulator to the board before this is soldered into the tinplate box as the capacitors near the 78M05 and R14 will be found difficult to solder afterwards. Do watch the polarity of the tantalum capacitors.

The input reverse polarity protection diode (not shown on the circuit schematic) is now an SMD rather than leaded type.

Prepare the tinplate box as shown on the following page , drilling holes for the SMA RF connectors and the DC feed-through capacitor. The input connector hole should be 10mm below the top rim of the box. The output connector hole should be level with the pre-amplifier output track. The feedthrough capacitor hole should be 10mm below the rim of the box and on the same box wall as the output connector. Both RF connectors can be drilled 3mm diameter, although the hole for the feedthrough capacitor should obviously be drilled to accommodate the actual capacitor used.

Mark a line 10mm below one rim of the box (a vernier caliper is ideal for this). This is the ground-plane position. Seam-solder the PCB into the box, taking care to ensure it is level and then soldered all the way round including on the component side at the regulator end of the box. It will be necessary to file small cut-outs in two corners of the PCB in order to clear the seam overlaps in the box.

Use small gauge solder (28swg - nothing larger) and a fine-pointed small soldering iron to solder all the components onto the board. Regular 22swg solder is **GUARANTEED TO MAKE A MESS OF THE BOARD!** Suitable solder can be obtained from Rapid Electronics of Colchester as a SMD rework kit. Regular 22SWG solder is probably best used only to assemble the box and for seam soldering the PCB.

Solder C1 onto the spill of the input connector. Solder L2 so that one end is on the track pad, as shown, and the other end is soldered carefully to the free end of C1. Solder L1 so that the bottom of the loop is free to be soldered to Tr1 gate. The spill of the input connector must be cut down so that it protrudes no more than 1mm inside the box.

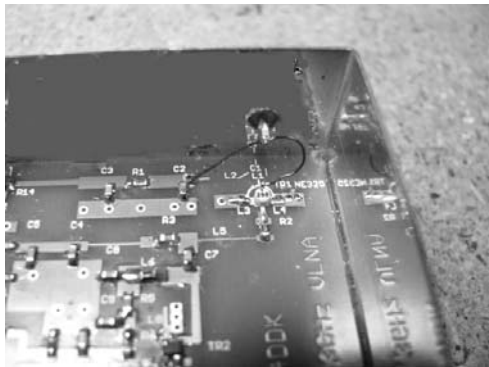

Board in the box information

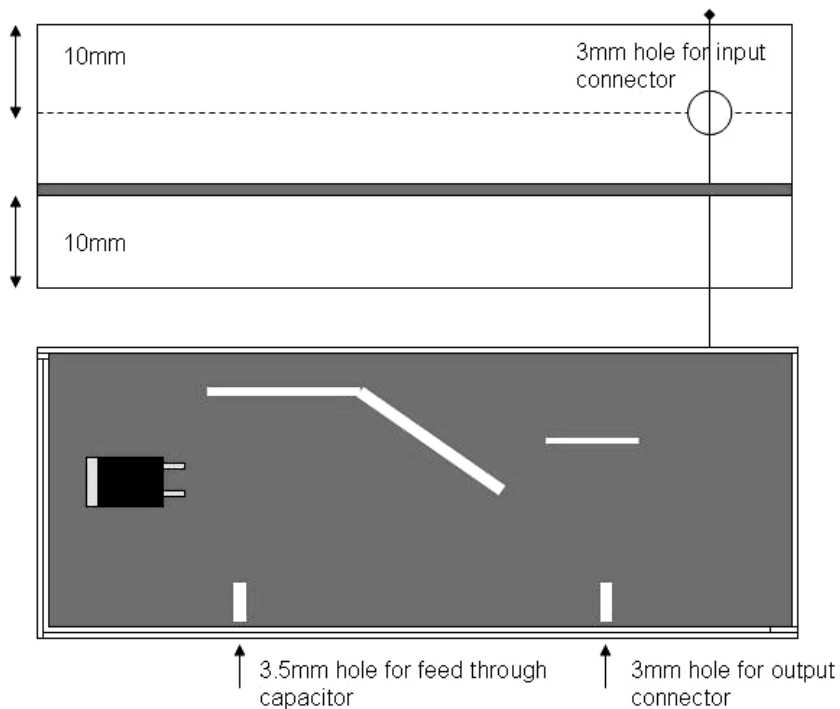
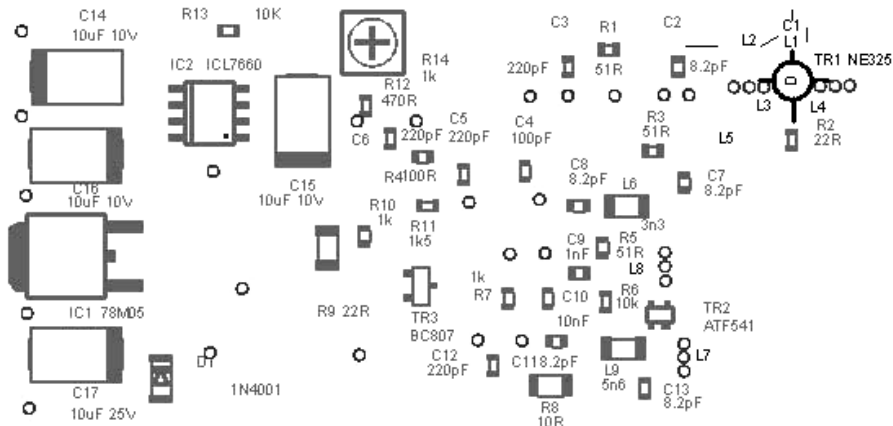

Fig 3 layout. This is for the 23VLNA. Tr1 is an ATF36077. C7 and 13 are now 4.7pF. L9 is 2n2H.



D1 can be soldered direct between the feedthrough capacitor and the (cathode - bar) PCB land or soldered onto the board in the place indicated, with a wire connection between the diode anode and the feedthrough. An SMD style diode will probably be offered in the kit. Solder in the two GaAs FETs after the initial setting up.

Initial Setting up

Connect +12v to +16v to the feed through capacitor. Check IC1 for +5 +/-0.2V at its output.

Check that the output of IC2 is -5 +/-0.2V. Check that the variable resistor R14 adjusts the output voltage at the free end of L1 over the range -1.2 to -0.4V. Initially set it at -0.8V. If any of these tests fail, check for incorrect component values or bad joints.

Solder the GaAs FETs into place, ensuring correct lead orientation, especially the leads of Tr2. It is best to use a small insulated soldering iron to prevent static damage. Touch the soldering iron TIP to the tin plate box before soldering the GaAs FET leads.

Correct the power supply to the box and adjust R14 so that Tr1 drain voltage is 2.0v. Also check that Tr2 drain voltage is about 3.0V.

Measure the noise figure. Now carefully bend the hairpin loop as shown in photo 2. Re-measure the noise figure. It should now be very low. Now CAREFULLY re-adjust the position of THE HAIRPIN for the lowest NF. Care here will be rewarded. Now go back and adjust R14 to obtain the lowest noise figure.

RF absorbent material should be stuck to the inside of the lid of the tin plate box. If using the supplied piece of ARC material, remove the protective paper from the rear of the absorber. Stick the absorber towards the end of the lid nearest the amplifier section. Putting the lid in place should not result in any increase in noise figure or loss of gain. This stuff is MAGIC!

The magnetic field absorber material supplied with the kit has been carefully selected to ensure stability.

Results

The pre-amplifier has had only limited testing at this time. The results are about in-line with expectations. An additional 3dB MIGHT be squeezed from the amplifier with some further circuit changes. Please remember that the PCB is FR4, not PTFE.

Expect <0.4dB noise figure and >25dB gain.

The prototype was tested between 2250MHz and 2350MHz with almost identical results and NO further adjustment. It is to be expected that the noise figure will remain sensibly constant across the entire amateur 13cm band (2300 to 2450MHz).

Caveat Emptor

The pre-amplifier is offered as a kit, the noise figure and gain achieved will depend on the individual constructor's ability with the soldering iron and patience in setting up the pre-amplifier.

The pre-amplifier should only be operated with the lid in place. This will keep out unwanted WiFi and other signals in the S band range.

However, without the high quality commercial magnetic field absorber material inside the tin plate box lid, putting the lid in place is guaranteed to degrade performance. Foam absorber, such as 'CMOS' foam, will not work very well in this application. Please use the right material. It is as much a part of the design as the FETs used!

For further information

Please Check my website for updates: www.g4ddk.com

73 from Sam, G3DDK sam@g4ddk.com

HEELWEG MICROWAVE 2008

In 2008, we are planning the 6th Dutch Microwave meeting for Saturday January 19th 2008. We are looking forward to meeting a lot of interested microwavers who can bring their home made equipment and we hope to serve them with the measuring equipment on site.

Best 73 from Eene, PA3CEG.



MARTLESHAM ROUNDTABLE 2007

A REPORT ON THE UK MICROWAVE GROUP'S AGM AND MICROWAVE CONVENTION

The eagerly awaited prestige event of every UK microwaver's year took place over the weekend 10/11th November 2007. We were not disappointed! The convention was a great success, with some 120 in attendance on the Sunday and maybe just under 100 on the Saturday. This year, the whole programme and venue was organised by the Martlesham Radio Society, to whom UKuG owes a big vote of thanks for an excellent job. The lectures were of a very high standard once again and had the added spice of a Continental flavour with speakers from Sweden, Germany and the Czech Republic. The USA was well represent with at least three callsign bearers seen. The trading tables did a brisk trade with loads of bargains and useful items including a couple of nice Spectrum Analysers, Power Meters and millimetre band components and modules. The 2007 Proceedings of UKuG sold well, though we think some of you forgot to get one so please turn to page 24 for information on how to obtain one by post!

The following pages include the AGM minutes, Annual Balance Sheet, photos and unsolicited reports from two of the attendees, G4HUP and GM4CXM. See you all again next year!

MINUTES OF THE ANNUAL GENERAL MEETING OF THE UK MICROWAVE GROUP

HELD AT THE MARTLESHAM ROUND TABLE , 12 NOVEMBER 2007

The meeting started at 10.00am

Apologies for absence: Mike Dixon G3PFR, Barry Chamber G8AGN

Present: RSGB President Angus Annan plus approximately 50 members of the UK Microwave group including the following committee members:

Brian Coleman, G4NNS	Chairman
Ian Lamb, G8KQW	Secretary
Steve Davies, G4KNZ	Treasurer and Contest Manager
Peter Day, G3PHO	Scatterpoint Editor
Murray Niman, G6JYB	RSGB Microwave Manager
John Quarmby, G3XDY	UKuG Awards
Robin Lucas, G8APZ	Assistant Scatterpoint Editor
Kent Britain, WA5VJB	USA liaison

Minutes of the 2004 AGM: Not available in paper copy

Matters Arising: Nil

Committee Reports:

Annual reports were presented by the Chairman - G4NNS, the Secretary - G8KQW and the Treasurer - G4KNZ.

In his report, **the Chairman** thanked the present committee for all the hard work they had put in over the past twelve months. He also made special mention of the invaluable work put in by **the retiring treasurer, G4KNZ**, and wished him all the very best for the future.

The Chairman then went on to outline the major achievements of the Group during the last year, one of these being the major work that was performed in upgrading and extending the UK microwave beacon network. Special thanks were given to those who have helped with the various beacon projects.

The Chairman highlighted the problem that increasingly more editorial help is needed for Scatterpoint, Proceedings and the Technical Compendium and appealed for volunteers to assist with the increasing administration tasks.

It was announced that a Round Table is to be held at Bath University on 20th April 2008, this round table would be held instead of RAL. He also mentioned that UKuG is hoping to run a more northerly round table in future.

The Chairman then presented the future plans for the group and again thanked everyone for their support during the past year.

The Secretary's Report confirmed the strong position of the Group as seen in its membership base. The membership is now more than 380. Two thirds of UKuG members take electronic Scatterpoint and almost one third pay using PayPal. The secretary mentioned the growing problem of having to chase members for renewals.

A summary report of the members' survey results was showing how the input has been used in the formulation of UKuG strategy and plans. Finally some UKuG website statistics were presented and members thanked for their ongoing support during the past year.

The Treasurer's Report showed that UKuG's finances are in excellent shape; during the past year the group had an income of £2920.70, spent £2809.43 and the closing bank balance was £7319.78. The treasurer highlighted that £1338.95 had been spent in support of the LEX, AZA and FNM beacon projects.

The treasurer presented a review of and comments on the 2007 UKuG contest programme, John Quarmy G3XDY is taking over from G4KNZ as Contest Manager for 2008. John asked members to provide comments / suggestions during the coming month and stated his intention to produce the 2008 contest calendar for publication in January 2008.

Election of Officers for the Year 2005-6:

Due to two committee members (MOEYT and G4KNZ) deciding to stand down this year there was an election to replace them. Two nominations were received as a result of which the following were elected to the committee:

John Worsnop, **G4BAO** proposed by G3XDY, seconded by G4DDK, returned unopposed.

Graham Murchie, **G4FSG** who was proposed by G4NNS, seconded by G8KQW, returned unopposed.

Graham Murchie **G4FSG** was also duly elected as Treasurer

A.O.B:

UKuG Constitution

The Constitution had undergone a modernisation review/revamp by the committee during 2006-7. The proposed document had been available on the UKuG web page during the past 6 weeks for comment and only positive feedback had been received by the secretary.

G8KQW proposed acceptance of the updated Constitution. This was seconded by Mike Dixon and carried by unopposed vote.

End of Meeting

MARTLESHAM ROUND TABLE 2007





Top left: John, G3XDY, receives the RSGB G6ZR 2.3GHz Trophy from RSGB President, Angus Annan

Top right: Chris, G0FDZ, was presented with the UKuG's G3VVB home construction trophy

Below: Ralph, G4ALY, the first recipient of the new UKuG G3EEZ Memorial Award for outstanding contribution to amateur microwave communications



Your UKuG Committee working for you!

Above: Ian G8KQW plays with his new toy found at Martlesham

Below: Graham G4FSg tries a short distance QSO on 10kHz!



Many thanks to the following for allowing us to use their Martlesham photographs:

Rainer, DF6NA,
Ralph, G4ALY,
Peter, G3PHO

UK Microwave Group Financial Report Nov 2007

Balance Sheet

UK Microwave Group		Summary of Accounts 2007		
		Covering period 01/Jan/2007 to 31/Dec/2007		
Item	Income	Expenditure	Balance	Notes
Opening balance 01/Jan/07			7208.51	
Subscriptions	2732.52			
Donations	8.00			
Proceedings	24.00			
Interest	118.02			
Other income	38.16			
Subscription costs		44.00		RSGB affiliation
Newsletter printing & postage		1027.61		
Proceedings		9.87		
Beacon support costs		1338.95		GB3LEX, GB3AZA, GB3FNM
Other expenses		389.00		Trophies, events, web, certificates
Sub-totals	2920.70	2809.43		
Closing balance 07/Nov/2007			7319.78	
<p>Note: The figures above do not include the very recent production costs incurred with the 2007 Proceedings book. These will be shown in next year's balance sheet.</p>				
<p>S. J. Davies G4KNZ Treasurer</p>				



Martlesham Microwave Round Table November 2007

Dave Powis, G4HUP / ND8P

Following just a few weeks after MUD is the prime microwave event of the UK calendar. This is one of a programme of 3 events that take place in the UK each year, co-ordinated by the UK Microwave Group. It is the largest, being a 2 day event which typically draws around 120 devotees each year from the UK, Europe and the USA.

There are similarities to Microwave Update (MUD) - we have two days of speakers; we have test equipment and measurement facilities, a Saturday night dinner and we have a traders/flea market area. In previous years, we have also operated an antenna test range facility but demand for that seems to have reduced at the moment.

There are also some differences from MUD - the event does not move in location each year - we are always hosted by the labs of the Telecomms company BT - but this means also we don't have the convenience of staying and meeting in the same venue - those who visit Martlesham stay at a number of local hotels.

The range of talks and presentations this year was very wide, covering aspects of construction, terrestrial microwave and EME operation, digital ATV techniques, remote station control, and common planning issues, such as beacon co-ordination. This event is also the venue for the UK Microwave Group's AGM, and some of the UK operating and achievement trophies are presented here, this year by the RSGB president Angus Annan, MM1CCR.

At the dinner on Saturday evening we were treated to an excellent after dinner speech from Angus, who admitted he was not a microwaver by experience, but had learned a lot from attending the event. The prime focus of his speech was on the theme of expanding interest in radio as a hobby and differentiating it from the 'commodity radio' (ie cellphones, bluetooth adaptors etc..) that have become such a part of modern life.

The UK Microwave Group is an active body representing the interest of microwave enthusiasts within the UK but also has a very significant overseas membership. 10 issues of its excellent magazine Scatterpoint are produced each year. Take a look at <http://www.microwavers.org/>

GM4CXM



Last year and the year before, I waited with baited breath, as a non- attendee, to read feedback from those that went to the Martlesham Microwave Round Table.

Nothing or little was ever mentioned on the UK Microwave Reflector so it was a case of waiting for Scatterpoint to appear

before getting a committee based aspect.

I imagine there is nothing worse for the organisers, speakers and helpers than reading the grapevine afterwords and yet nothing is said after all the work put in by those involved to provide visitors with a worthwhile and enjoyable experience.

Even negative feedback can be positive if it leads to an improvement.

As this was the first MMRT I have attended, I have no point of reference as to past events. Personally, I found the whole experience very enjoyable and worth the expense and effort required to make the journey. It was also made possible by invaluable transport help from/to Stansted Airport and around Ipswich by both Ian, G8KQW, and Bryan G8DKK.

I would also like to thank Graham, G4FSG, for offering to organise airport transport for those travelling from Scotland, as this last leg of the journey

was a deciding factor of attending or not.

The meeting was an excellent balance of social and technical. It was great to meet friends, old and new, put faces to callsigns and get to know those I work on a regular basis.

The talks were both interesting and thought provoking.

The dinner was very good, though we do tend to get slightly larger chicken up here despite them often getting chased by haggis!

The test facilities were kept going every time I visited the room, so well done to John, Sam, Lehane and others assisting.

The young ladies did an excellent job with supply of rolls and beverages.

What makes the success of this event more surprising is that there is no charge other than for the dinner. I do not think a small charge or donation box at the reception would be amiss to raise some additional funds for UKuG and MRS and perhaps a small donation for each item tested/measured if you use those facilities. I would also suggest that the organisers consider no charge for guest speakers for rolls and beverages.

So ... thanks to all involved for all you did to make MMRT 2007 a success.

73 from Ray GM4CXM

24GHz Short Range Radar

Ofcom has recently published proposals to amend regulations to require certain Short Range Radar equipment in cars in the 24GHz band to be automatically deactivated when operating within areas around five UK radio astronomy sites. This is in order to protect these sites from harmful interference. The document can be found at:

<http://www.ofcom.gov.uk/consult/condocs/srr/>

MICROWAVE ROUND TABLES 2008

BATH 2008

UKuG can now confirm that we are booked in for the round table at the **University of Bath on Sunday 20th April 2008**. This will replace the RAL meeting traditionally held around that time. The reasons for the change are: (1) to give RAL staff a well deserved rest. (2) To build a relationship with a University who work in the area of microwave communications and 3) to work with the university to build, install and run a beacon (at least in part) as a student project. This is likely to be on 9cm and would be co-sited with the GB3UB 70cm repeater. UkuG Chairman Brian Coleman, G4NNS, hopes that this might act as a template for developing relationships with other universities and thus stir interest in (microwave) amateur radio in a new generation of students.

SHEFFIELD 2008

UKuG and Sheffield Amateur Radio Club are joining forces to hold the first **Northern Microwave Round Table** of the 21st century over the weekend of **12-13 July, 2008**. The venue will be the SARC Club rooms at the Sheffield Transport Sports Club, near the Meadowhead roundabout, in the south of the City. There is easy access from the M1 and the A61.

Saturday will be a Microwave Workshop (Intermediate level) aimed at those who have recently got on to microwaves or have already attended a Beginners' workshop. On Saturday night we hope to hold an informal gathering (including a meal) at a local hotel or pub. Sunday will be a full Round Table meeting with lectures, some test gear (including an antenna test range) and fleamarket, etc. Visitors from outside the region may care to travel up to the event during Saturday in order to attend the social function. The club rooms include a radio shack, ample off road parking and extensive sports fields. Sandwiches, tea, and coffee will be available on both days at the sports club house, where there is also a licensed bar. The meetings will start at 10am and finish around 4.30 each day.

Sheffield is ideally located for a long weekend holiday. In addition to a large number of interesting things to see and do in the city, you will be within 15 minutes drive of the Peak District National Park. Details of suitable accommodation will be posted here in Scatterpoint during early 2008.



Transitions for Small Waveguides

Paul Wade W1GHZ ©2007
w1ghz@arrl.net

Coax cable is not normally used at 24GHz and above since losses are very high and suitable connectors are hard to come by. Recently, however, I had a couple of requests for transition dimensions for waveguides smaller than I had covered in my recent *QEX* article¹. The reason for using a transition is to make connection to an active circuit which uses coax or microstrip – it's hard to get a transistor operating inside a waveguide.

I used the same technique described in the article to calculate dimensions for waveguides as small as WR-10 at 76 GHz, with results shown in the table below. I have not built or tested any of these, but they should be pretty close.

Waveguide	Freq	Probe	Probe	Backshort
GHz	Dia	Length	Distance	
WR28	24	0.5mm	2.4mm	2.14mm
WR28	38	0.5	1.76	1.7
WR28	47	0.5	~1.8	~1.8 ***
WR22	38	0.5	1.5	1.5
47	0.5	1.43	1.35	
WR10	76	0.25	0.735	0.714

*** WR28 NOT RECOMMENDED at 47 GHz. (The book range is 26.5 to 40 GHz.) With the transition probe in the center of the guide, there is a large resonance at ~50 GHz, upsetting the transition operation at 47GHz enough so that there is no probe dimension that gives decent return loss.

1. P. Wade, W1GHZ, "Rectangular Waveguide to Coax Transition Design," *QEX*, Nov/Dec 2006, pp. 10-17.
(available at <http://www.arrl.org/qex/2006/11/wade.pdf>)

CONTEST ACTIVITY

A review by John Wood, G4EAT

Introduction

There continues to be much discussion on the reflector with regard to contests, activity levels and use of 2m and KST for talkback.

I think everyone is concerned at the "apparent" decline in levels of activity but most comments so far have been emotional and subjective rather than applying objective analysis. Some have speculated a decline in activity as having a direct relationship to talkback diversity and concluded that the rules should be changed! I believe that any changes to the rules should only be those that are intended to increase activity and are backed up by objective analysis that has been made for each contest. The purpose of this brief study is to provide some objective data for analysis and discussion.

Each contest has its own unique factors: UK 10GHz Cumulatives are as different to UK 24GHz Cumulatives as also are the UK Low band contests and then the Multiband IARU. To win requires contestants to study the rules and then apply best "Horses for Courses". Sometimes the use of 70cm and then QSY up the bands is much more effective than 2m or KST.

10GHz Cumulative Data.

I have participated in all of the contests mentioned above but have much more extensive data for the UK 10GHz Cumulatives than any other contest. The following is my analysis, extracted from my Log Books, for the last 5 years of UK 10GHz Cumulatives. These have been 5 or 6 sessions, each of 11 hours, on Sundays during the summer months.

This data is based on my logbook entries and should be valid for this particular contest since I have operated for many hours in almost all sessions for the last 5 years+ (sad eh!).

I have used two methods for talkback: (Almost no direct QSOs on the band)

- 144.175MHz: I am now using 350W on 2m so I can be heard (this does not mean I can hear the distant station loud and clear!).
- KST: I monitor/use KST 24/7 as well as in these 10GHz contests.

Average number of QSOs per session:

2003	2004	2005	2006	2007
19	24	25	30	18

Average number of QSOs per session with G(W) portables:

2003	2004	2005	2006	2007
8.5	10	9	8	7

Total number of QSOs per with G(W) home station:

2003	2004	2005	2006	2007
33	50	60	88	38

Total QSO's using 2m/KST for talkback

2003	2004	2005	2006	2007
66/29	74/47	69/56	77/74	48/44

Data Summary

- QSOs per session - there has been an encouraging general increase in the number of QSOs year on year **until this year, 2007!**
- The number of G(W) portables has seen a slow decline but note 2003 was also low.
- QSOs with G(W) home stations. There has been a steady increase in home activity, year on year until this year. **This has been the biggest single factor for the overall decrease in 2007.**
- Use of KST vs. 2m for talkback. 2 metres is still very important for setting up QSOs. For me, I still have more QSOs obtained via 2m rather than KST but there is a steady increase in operators, both from home and /P, being on KST. (Page scrolling is not an issue in this contest since the number of users is far less than that for the IARU contests). You could argue that the adoption of KST has helped increase the total number of QSOs possible.

In summary, it would appear healthy that from 2003 to 2006, the total number of QSOs has increased as well as the total number of home stations (may explain small dip in number of /Ps).

The question to be answered is why was 2007 so poor?

Possible Factors to Consider for Explaining the 2007 decline

Radio conditions:

Enhanced tropo conditions or RS are what everyone hopes for to increase their points score, work someone new and maybe work a new square. As normal for contests, enhanced tropo rarely coincides with contest so ODX for each contest has rarely varied much.

G4EAT ØDX

2003	2004	2005	2006	2007
402km	402km	464km	464km	464km

The additional benefit on 10GHz is that there is always the possibility in the summer months for RS to provide extended paths.

Total Number of RS QSOs

2003	2004	2005	2006	2007
3	2	9	4	1

2005 was an exception but as always the problem for the contest organisers is that it is not possible to pre-arrange the radio conditions!

Expeditions:

My definition is a /P station operating from a square that is rarely activated e.g. JO03.

Total number of Expedition QSOs

2003	2004	2005	2006	2007
4	7	3	1	0

Is it a coincidence that one ingredient of the poor year is no Expeditions?

Personal Observation and Interpretation of Data

Dxpeditions:

Dxpeditions to rarely activated squares give contestants a new multiplier and, for some home stations and our continental cousins, a chance to work a new square for the first time. The interest at times creates a long waiting list for the DXpedition station and usually results in many other QSOs for all concerned.

Conversely, when /P stations announce that they will not be QRV for a session there is a noticeable drop in activity. Perhaps home stations have the thought that they cannot be bothered to work the "same old" stations and paths.

Continental participation

Non G(W) QSOs

2003	2004	2005	2006	2007
18	21	19	19	16

I thought before I 'crunched the number', that we have had a drop off in the number of continental stations active. The numbers do not agree and indeed held up well this year making up for the loss of G home stations. (I realise I am also fortunate to be well located for F, ON, PA and DL stations). For the same reasoning as Dxpeditions, more Continentals participating would help provide some motivations perhaps for home stations and all participants.

Recommendations

The data clearly shows that to increase activity from the 2007 lows, requires more of the home stations to participate. If my "guesses" as to home station motivation are correct then perhaps some of the following may help:

- Encourage expeditions. Maybe a new Trophy for best DXpedition?
- Encourage more Continental participants. Separate contest sections/Trophies?

These are just some ideas that spring to mind but I welcome all other ideas that help.

To win a contest is to work all possible QSOs, so the use of KST is essential as a complementary tool. Banning the use of KST would be a retrograde step and would decrease the total number of participants, since many have 2 metre TVI, or no space on their mast for a VHF array (as microwave antennas take priority!) and they would be lost as participants. Use all available means for talkback and encourage other to do the same.

73 and good microwaving!

John Wood G4EAT

Editor's comments:

Many thanks John for the most interesting and valuable research into contest activity. As an almost 100% portable operator, I can vouch for everything you say and, indeed, am partly to blame for the fall off in 2007 activity! Over the past couple of decades I have tried to activate as many "rare" squares as possible such as IO71, IO72, IO73, IO84, IO85 JO03 and the like, so that everyone, including our Continental neighbours has a reason to get on the bands. During 2007 I took a conscious decision to wind down the scale of my expeditions for a number of reasons.... the prohibitive cost of transport (diesel in my case) and the fact that only a couple of other stations (contest groups in fact) seem to have a sense of adventure and travel long distances for the sake of the rest, many of whom are home stations. I now believe it's time that a few others have a go at putting these places on the microwave map, so how about it folks? I believe there's little to be gained from using the same, semi-local, portable location month after month. While I aim these comments at all microwave bands I'd like to make a special plea for more imagination to be used when planning /P activity on 24GHz and above. There are useful /P locations north of latitude 51 degrees North you know! OS maps and a few prior "reccies" are needed.

Readers' comments are earnestly invited ... 73 from Peter, G(M)(W)3PHO/P



ACTIVITY NEWS FROM THE WORLD ABOVE 1000MHz

By Robin Lucas, **G8APZ**

The October column was being finalised as the microwave bands opened up. I was able to cover some of the DX worked on 11th October but the good conditions continued (mainly in mainland Europe) until 14th October.

It is quite interesting to have a look what was going on in the upper atmosphere at the time of these openings and there is more on this later in the column.

The day after I had sent the column to the Editor, we learned about a first on several microwave bands between G and EA. It was possible for Peter to get the news into Scatterpoint just hours before it went to the printers.

The contacts between Ralph, **G4ALY**, (IO70) and **EA2/F2CT/p**, (IN93) were "firsts" on **13cm**, **6cm**, and **3cm** and were made following numerous attempts in the past, over several years. The previous attempts had failed, due to the weather and propagation conditions but, after all, Spain is a long way away on microwaves. Congratulations to both of them.

NEW BEACONS

The new Farnham beacon complex **GB3FNM**, (IO91OF07) went "on air" on 13th October. The frequencies (MHz) are **5760.920**, **24048.920** and **47088.920**

The **6cm** beacon has been heard by **ON4IY** (JO20), **G3LQR** (JO02), **G3XDY** (JO02) and **GW3TKH** (IO81) whilst the **24GHz** beacon has been heard on a regular basis by **G4EAT** in JO01 at 113km. On 16th November, it was 579 at 9am.

The **47GHz** beacon has been heard at S1 to S2 by **GOJMI** at his portable site Holybourne Down, (IO91ME) about 12km away, and this appears to be the first reception report for this beacon.

In a note from Mike, **GOJMI**, (IO91MD) Alton, Hants., he reports hearing the **24GHz** beacon over a non optical path, receiving it on his 2' x 3' "mesh flyswatter" at 25'.

The 6mm square mesh is thought to be too big for **24GHz**, but this is indeed very encouraging, given the reputation that Alton has as an RF "black hole".

5.7GHz/10GHz ACTIVITY DAY

From: M. Vincent, **G3UKV**
Sunday, 23 Sep 2007

Thanks to stations worked from Long Mynd (IO82NN) - **G3VKV**, **MOGHZ**, **G4ZXO/G4WYJ** on both bands, plus **G4EAT** on **3cm** only. Ralph, **G4ALY** tried both bands, but there was nil either way.

The site wasn't on the summit of the Mynd, but it was still fairly well sited. Conditions seemed poor, including 2 metres. The best DX was **G4ZXO/G4WYJ/P** at 263 Km on both bands. The difficulties of running 'KST portable are well documented, so we didn't take the laptop.

When I got home, I checked and noted about a dozen 'G' stations used **3/6cm** via KST whom we did not hear at all on 144.175 MHz. There IS life up here but it takes two to tango.

For those without 2 metres, there was always the phone. Microwave activity seems to be on a downward spiral this year, combined with indifferent propagation much of the time.

73, Martyn **G3UKV**

Several points from Martyn's comments provide food for thought.

John Wood, **G4EAT** has written an article in this issue of Scatterpoint (P.13) which looks at reduced activity.

As regards using 'KST under portable conditions, apart from lack of cell phone signals, I am not aware of what the difficulties are. Your views on both these issues would be welcome.

The October Lifts

Some more news of the openings around 10th -14th October comes from Marc, **F6DWG/p**, in JN19AJ. He worked some

long distances on **13cm**, **6cm** and **3cm**.

On **10th October**, **SP6GWB**,(JO80JG) 1061km (519/519) was worked on **10GHz** and on **13th** at 1640utc **OZ2LD**,(JO54TU) 893km. On **14th** at 0731utc **OZ1CTZ**,(JO46OE) 896km on all three bands, and the "icing on the cake" at 0946utc in the shape of **SM6AFV**,(JO67GQ) 1151km also on all three bands. Reports on **3cm** were 519/519 peaking 579 at the end for Marc's first **SM** on **3cm**.

Marc runs 80w/90cm on **13cm**, 30w/90cm on **6cm**, and 30w/90cm on **3cm** (all home made).

From: Gordon, **GOEWN** (IO93FK) in Sheffield, comes the following report ...

12th October

Having noticed the possibilities for an opening earlier in the week, I finally got around to erecting an antenna for **23cm** on Friday 12th. Like others it was frustrating to see all the activity taking place just over the North Sea and not to be able to join in the fun.

Conditions were 'normal' or even slightly down for much of the time both on **23cm** and **3cms**, the bands on which I was operating.

13th October

Checking again early Saturday morning things were still 'flat'. However, at around 10am, I noticed a large increase in the strength of the Martlesham **23cm** beacon. I quickly arranged a test on **23cm** with Gerd, **DJ5BV**, via 'KST' and a pleasant QSO followed with 59 reports exchanged both ways.

Then I was 'meeped' by **OK1JKT/p**, (JO60RN) who wanted to test **3cm**. I was a little sceptical but changed to **3cm** where almost at once I located Karel's signal, a stable 519. This was another **3cm** contact over 1000km -- 1071kms to be exact. The band conditions then collapsed for about a hour with no DX beacons or DX audible.

At 11:30am it came back to life again and I started hearing **DBOVC**,(JO54). **OZ2LD** was active from JO54TU so a test was arranged resulting in 529/549 reports. This was followed by **SK7MW**,JO65MJ, and 55/57 reports were exchanged. Once again the band collapsed and nothing more was heard on the Saturday.

14th October.

I was up at 5am, but on checking found the

band was 'flat'. Conditions seemed poor with warm temperatures, heavy drizzle and a breeze. After a few more hours in bed I checked throughout Sunday but things remained flat until around 5.00pm when the bands opened again for about 20 minutes, first signalled by the **HB9EME** beacon becoming audible on **23cm**.

I quickly arranged a test with Arnold, **HB9AMH/p** and we completed on both **23cm** and **3cm** (57/57) at a distance of about 980km. After signing with Arnold on **23cm** I was called by **DF6IY** in JN48EU and we exchanged 52 reports. The band closed quickly after that.

My impression is that I was located on the 'fringe' of this event and was only able to access the ducting briefly. These brief 'openings' were spotted by monitoring the band and various beacons. More casual operation would have missed these half-hour spells of enhanced propagation.

Here in IO93, this event was not a typical 'autumn' tropo event; this was a 'cloudy high' with warm temperatures (14c overnight low!) and drizzle. **73 Gordon**

24GHz

Gordon had another crack of the whip later in the month. This time it was on **24GHz** where he uses a 500mw TX, 45cm ProComm dish/ feed, and receiver NF 6dB (measured at Martlesham in 2005)

23rd October.

On returning home after work on the evening of the 23rd, I (**GOEWN**) checked band conditions by monitoring **23cm** beacons. Pressure was still high following a warm, sunny autumn day and an obvious 'layer' was visible looking at the horizon. Things were definitely looking up! Sure enough beacons to the east were well above normal. Martlesham was 599+ on **23cm**.

Whilst I was still getting sorted John, **G4EAT**, called me via 'KST' where we arranged a test on **23cm**. John's signal was 59++ so we QSYd to check **3cm**. Here signals were also strong but with some QSB, ranging from 58 to 59+, so certainly worth a shot on **24GHz**. I quickly arranged to take down **3cms** and replace it with my portable **24GHz** station, which took some 35 minutes or so.

Once ready, I contacted John, again via 'KST'.

located his signal. John was 559 and gave me 529, though in both cases there was QSB. At the top of the cycle John was 599 over this 241km obstructed path.

Shortly after, I tried with **G4BAO** and **G4DDK** but both tests were sadly unsuccessful (Either would have been a new square on **24GHZ!**).

Rechecking the beacons showed conditions had collapsed. Martlesham was back to normal or even below on **23cm**. **G4EAT** noted via 'KST that there is often a brief strong enhancement about two hours after sunset.

We put this contact down to some form of ducting but not a classic 'radiation duct', which normally gets stronger overnight and peaks before sunrise.

The mechanism is still somewhat of a mystery. The temperature on the evening of the 23rd was dropping quickly to around 5c at the time of the contact, meaning the losses due to water vapour were probably relatively low. **Gordon, G0EWN**

REGULAR TROPO TESTS on 23cm

Ken Willis, **G8VR**, (JO01RJ) North Foreland, Kent, sent some details of his **23cm** tests.

".... the ON4KST chat site is a great boon for **23cm** operators. By arranging spot tests it has been a great surprise to find what can be worked under "flat" conditions. Over more than 20 years on **23cm** I had never heard the Cornish beacon nor a single station in that county, but since logging on to 'KST I have found that I can work **G8ARM** in Penzance virtually every time we try, sometimes barely readable, but always there.

Similarly I heard and worked only 2 GMS in about 20 years on the band but, via 'KST "immediate" tests, I find I can work **GM4LBV**, (IO86RQ) most times, and **GM4XCXM**, (IO75TW) also - sometimes aircraft assisted. In other words, if someone is listening for you on a given frequency the chance of a QSO is very high despite the conditions up to a certain (but so far undetected) distance of course, though that distance seems to be well in excess of 500km if the far-end station has a reasonable take-off.

So please encourage people to use this resource at all times of the day. I still find the hobby exciting after more than 70 years".

Ken believes he may be our oldest **1296MHZ** operator still QRV. He was licensed in 1937, and was 18 at the time, so he has held his callsign for 70 years so far! Does anyone know of anyone who can beat this? (*Bill, G6XM?...editor*)

SKEDS WANTED - IO94

Marc, **F6DWG/P**, JN19AJ is looking for skeds with stations in IO94 square, especially on **3cm** He has needed this square for a very long time! If you are in IO94, or have any information about stations who can be QRV, please email Marc at <fabriema@wanadoo.fr>.

DXpedition on 23cm to IO95

Ray James, **GM4CXM** took the opportunity to combine a family caravan holiday with some radio between 13th and 19th October, 2007. He ventured south of the border into IO95 and although the intention was to focus on 2M meteor scatter, Ray took some **23cm** equipment with him to put this rare square on the map.



Ray inside the cold caravan awning

Operating as **G4CXM/p**, the DXpedition QTH was at Old Hartley, near Whitley Bay (IO95GB) on a cliff overlooking the North Sea. Ray had stayed there once before but without any radio equipment and realised the potential to provide IO95 for those missing the square.

Unfortunately, no lift was experienced during his stay. **23cm** beacons which were audible all of the time were **GB3ANG**, **GB3EDN** and **GB3MHL**. **GB3MLE** was heard on one occasion, albeit, very weakly.

Completed QSOs: **PA2M** (JO211P) 559km,

G8VR (JO01RJ) 452km, **G0RRJ** (IO91FE) 431km, **G3LTF** (IO91GG) 422km, **G4EAT** (JO01HR) 396km, **G4BRK** (IO91HP) 380km **G3XDY** (JO02OB) 377km, **G4FSG** (JO02PC) 376km, **G8DKK** (IO91VX) 353km, plus at lesser distances, **GW8ASD**, **GM4LBV**, **GM4JTJ**, **G4CCH**, **GM3SBC**, **G8GXP**, **G4FVP**, **MODTS**, and **G8PNN**.

Unfortunately, the QSO with **G8KQW** was missing the final RRR so was incomplete. Other stations heard but not complete were **G4RGK**, **PA5KM** and **DJ5BV**.

Ray used an FT736R(10W), a 23el **F9FT** antenna at 14' (4M) and an SP23MK2 LNA.

OCTOBER DUCTS - Upper Air data

The University of Wyoming has a website at:

<http://weather.uwyo.edu/upperair/sounding.html>

It keeps historic soundings for radiosonde ascents. This includes data for Europe, and of particular interest are the Skew-T diagrams (see screenshot below) in conjunction with the data in text lists around these dates.

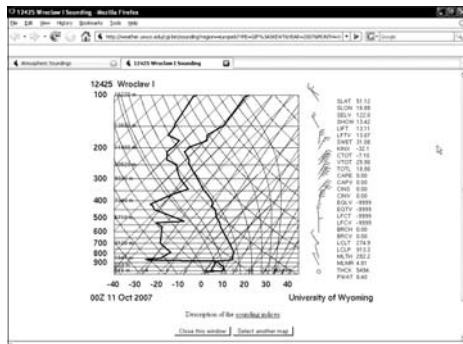

If we look at the text data for Wroclaw at 00:00z on 11th October 2007, we can see that at 1346m, the dewpoint drops very rapidly. It goes from -0.8C to -30.6C (left hand trace) accompanied by an increase of 4.8 degrees in the air temperature (right hand trace), and at the same time, the relative humidity drops from 84% to just 5%. At 1413m the temperature has risen further to 7.8 degrees. The temperature gradient starts dropping again with height somewhere around 1500m and does not return to the 1200m temperature until 3000m. Thus we have a layer of warm, dry air forming this very high level duct.

It is clear to see from the 12z soundings for

11th October that the temperature inversion responsible was between 1400m and 1800m in height. Data for Wroclaw showed a negative temperature at 1200m and +7C at 1400m, with Emden-Flugplatz +9C at 1500m, Meiningen +9 at 1600m and Essen +9C at 1800m.

For comparison purposes, have a look at the equivalent 12z soundings for **11th November** which shows the normal decrease in temperature with height.

NEW WSJT DIGIMODES

A number of experimental digital modes have been announced by Joe Taylor, **W1JT**. These may work on the higher microwave bands where existing modes do not. It would be a real step forward if any of these modes (JT4F?) work on **10GHz** very weak signal paths.

Because these modes are experimental, they will not necessarily form part of future releases of WSJT. Details can be found at:

http://physics.princeton.edu/pulsar/K1JT/JT4_JT4.TXT

EME

Rob Swinbank, **MODTS**, (IO94IL) made his first QSO on **23cm EME** on 30th October. This was with Howard **C4CCH** using JT65 who received his signals at best -26dB.

Rob uses a home built 2m mesh dish, and his modest power output of approximately 35W was fed to the newly fitted Septum feed from **OK1DFC**.

... AND FINALLY

The results of the 2007 **1.3GHz & 2.3GHz** Trophy Contests have just been announced, and it is very disappointing to see the adjudicator commenting on "the lowest number of entrants for several years with general UK activity reported as being at a poor level."

The "usual suspects" featured in the top positions, with **G3XDY** leading the Single op fixed category on both bands, **M1CRO/p** the **1.3GHz** Open section, and **G3OHM/P** the **2.3GHz** Open section.

With this last issue of Scatterpoint for 2007, we are approaching the time for New Year resolutions. We could resolve to add another microwave band to our home station, be more active on the bands we already have, increase our output power, maybe finish a project started some time ago ... or even send the odd activity report to this column!

Please remember to send your activity news for this column to:

scatterpoint@microwavers.org

For Disposal

From: "Adrian Warburton"
<adrian-w@blueyonder.co.uk>

I have in my possession various bits of kit that may be of some use to UKuG members:

Various bits of WG16 type flexi waveguide, an X Band cavity wave meter and slotted line, a Gunn diode oscillator built by me to a Mullard (I think) design, an X band horn onto a short length of WG16 with a type 'N' connector output plus couplers and adaptors.

I also have an X Band Raytheon Klystron with its details but no power supply. In addition I have an X Band spectrum analyser, designed by MIT in the 1940s. It has a small CRT and a 2K25 Klystron. It worked about 35 years ago and may still do so if it was slowly wound up on a Variac to reform the electrolytics. It 's probably too old to be any use but it should at least be in a museum!

I live in the Kent area and if any UKuG members might be interested, I would be happy to see them

Regards Adrian Warburton

ONLINE MICROWAVE MUSEUM

At the Crawley Round Table in September this year, Allan G8LSD took a large number of photos of a variety of 'historical' microwave equipment that were to be used on the microwave museum website. He has now updated that website and you can certainly see the difference, as it is at least double the original size. Have a look at:

www.microwave-museum.org

and see the new exhibits. By the way, Allan is always looking for more photos, so if you have anything suitable then please contact him at allan@r-type.org.

73 from Chris G0FDZ



UK Microwave Group



Proceedings

2006-7

NOW ON SALE!

2006-7 CONTENTS

G3PHO	Foreword
G4JNT	Using GPS to Enhance Amateur Communications
G4JNT	The Next Generation of Amateur Beacons for the 21st Century
G4NNS	Farnham Microwave Beacon Operator's Guide
G8UBN	The Microwave SDR Project
G0RRJ	Building the Kuhne Electronics 23cm TVTR Kit
WW2R	Backyard Microwave EME
G4NNS	Adventures in 24GHz EME
G4EAT	More on Operation of a 24GHz Home Station
WW2R	VHF Drivers for Microwave Local Oscillators
G4DDK	134GHz - The New Frontier
WW2R	A 134GHz Expedition to England
G0MJW	Microwave Propagation
G3OKA	The Practicalities of Cylindrical Cavities
G8APZ	Organising a Multiband Microwave Contest Entry
G3XDY	Noise Figure Results: Martlesham 2006

A limited number of the **The Proceedings of the UK Microwave Group for 2006-7** have now been published. After the sales at the Martlesham Round Table in mid-November, the remainder were advertised on the UKuG website. There are still a few left (maybe 40 or so by the time you read this) so, if you're interested, place your order with the UKuG Secretary, **G8KQW**, via the email address or phone number shown on **page 2** in this issue of Scatterpoint.

You might also check with Robin Lucas, **G8APZ**, who is handling the distribution of the book, if there are copies still available. His email address is: robin.lucas@ntlworld.com

Prices inc Postage & Packaging:

UK: £7

Europe: £9 or €14

Rest of the World: £12 or \$25US

Payment can be in either cash (UK Pounds, US Dollars or Euros), UK Sterling cheque or via Paypal. Please add 4% to the above if you use PayPal. We prefer PayPal.

We are sorry but we cannot accept credit or debit cards.